

# 1

## Overview: *ProTekTor+*

The *ProTekTor+* infrastructure monitor provides status and control of critical equipment at unattended remote sites. Located with the equipment to be monitored and controlled, the *ProTekTor+* communicates with the technician over the Public Switched Telephone Network (PSTN), radio link, or TCP/IP Ethernet.

### System Features

The *ProTekTor+* can monitor up to eight general purpose inputs. These inputs may be configured to operate in analog or digital modes, and are available with a variety of characteristics. Each analog configured input has user-defined upper and lower limits, time delay, qualifier, schedule, and scaling factors and can measure voltages of 0-5 VDC and 0-50 VDC of either positive or negative polarity. Each digitally configured input has user-defined active level, time delay, qualifier, and schedule parameters. The *ProTekTor+* automatically maintains a cumulative count of each input's active time for the current and previous day. In addition, all enabled input active times are logged in the `History` at the end of each day. The status of any input can be determined by modem. The *ProTekTor+* can be user-programmed to generate major or minor alarms upon failure of any monitored input, and alert the user via modem. The monitor will also notify the user when an input returns to normal, if so programmed.

The *ProTekTor+* has four relay-driver outputs, which may be optionally replaced with internal relays. Each output can be programmed to function as normal, latching, or momentary types, and can be remotely controlled or can respond automatically as programmed by the user.

Additional *ProTekTor+* features include input activity tests, scheduling of relay and alert calls, and the logging of all monitored events to the `History`.

The user can interact with the *ProTekTor+* locally by RS-232C port or remotely by modem. The *ProTekTor+* will automatically generate an alert call to VDTs, printers, or alphanumeric pagers. The *ProTekTor+* can also make a status call at user-programmed intervals of one to 255 hours. This allows all PageTek products in a system to "report in" automatically if desired to meet FCC monitoring requirements.

The *ProTekTor+* is powered by direct 12 VDC input or via a 115 VAC wall transformer.



# 2

## Installation

### Pre-installation Inspection

(in-shop)

Carefully unpack your *ProTekTor+* and inspect for any damage. You should have one each of the following:

- *ProTekTor+* monitor
- DC power cable with connector
- Interface connector
- This manual

Optionally you may receive one or more of the following:

- Telco cable terminated at each end with RJ-21M connectors
- Type-66 punch block and bridging clips
- Wall mount AC power supply
- Current (tower light) sensor
- External temperature sensor and associated cable
- Telewave™ RF power sensor and associated connectors

The default input conditioning will generally support two 50 VDC analog inputs, two 5 VDC analog inputs, and four contact closure inputs. Note that an alternative input mix may have been requested at the time the monitor was ordered. If any change to the input conditioning is required, refer to the **Pre-installation Set up** section following this page.

As there are no internal adjustments, there is generally no need to open the *ProTekTor+* housing unless alternative input conditioning is required. If this is so, we suggest that internal adjustments be made in-shop before going on-site to install.

See "Pre-installation Set up," p. 4.

# Pre-installation Set up (in-shop)

See "Configuration Plug Descriptions" Appendix, p.37.

Add Telewave Sensor plug on S1-S8.

## Input Conditioning Configuration

The personality of any input is determined by the type of input conditioning plug installed. Available plugs support 0-5 VDC and 0-50 VDC scaling of either positive or negative polarity. Digital plugs supporting TTL and EIA digital levels and contact closures are available. Alternative plugs are available upon request for other input conditioning needs. The type of plug is generally read by the system and the appropriate scaling and set up performed automatically. Refer to the documentation associated with your sensors or equipment to determine what type of configuration is required. Note that it is always best to use the lowest scale possible to achieve the best accuracy and resolution.

The following diagram is provided to assist in the installation and configuration of different input conditioning plugs. Also see descriptions of configuration plugs in Appendix A, p.37.

## Input Conditioning Configuration Plugs and PCB Layout

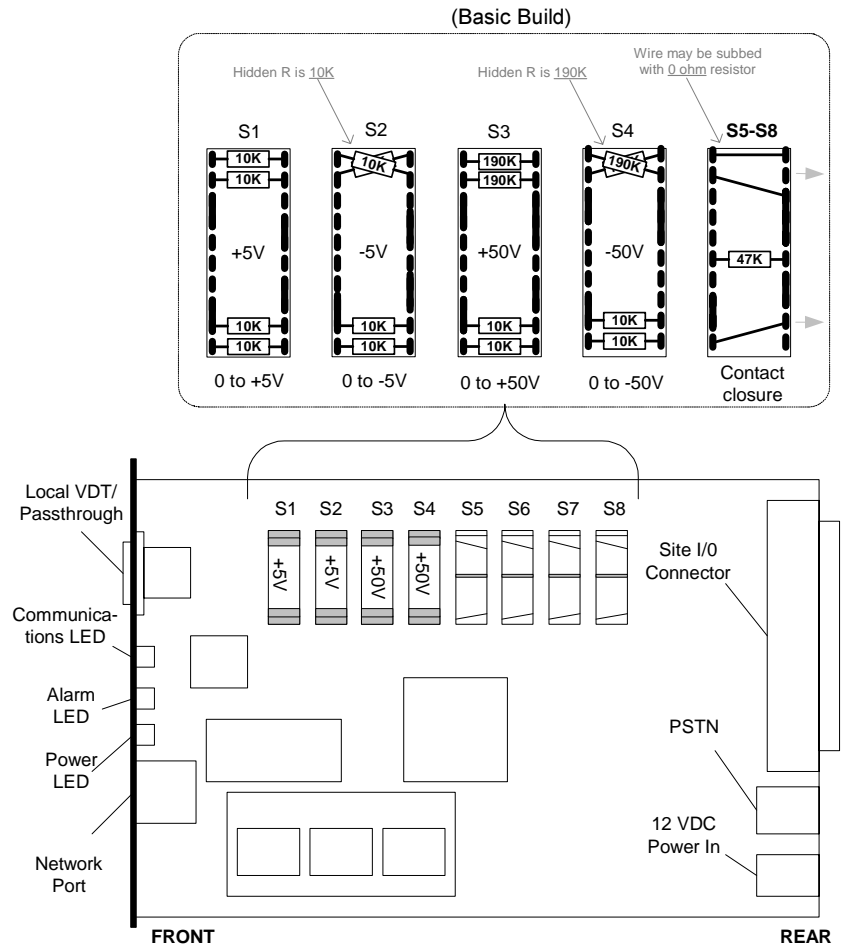

The *ProTekTor+* basic build inputs are permanently configured to contact closure mode and do not support input conditioning plugs. Any change in input configuration on these units will require replacement of soldered components. Note that configuration may look different from the above diagram depending on the build requested from the factory.

## On-Site Installation

### Interface Connector Installation

Attach the terminated end of the interface connector to the port labeled “Interconnection” at the rear of the *ProTekTor+*. All inputs and relay or relay-driver outputs are present at this 25-pair interface connector. Though the standard connector is a solder cup male RJ-21 without cable, a variety of interface connection methods are available. Refer to **Interconnection Options** below for more information.

The *ProTekTor+* has 12 VDC on pin 25 for the powering of external low current devices. *A table showing the connector pin-out and connector color code and a diagram of the pin locations can be found in Appendix B.* Note that each functional pair uses a standard Telco pair.

See “Rear Panel” layout diagram to locate ports (Appendix A, p.43).

See table and diagram for more information (Appendix A, p.40-41).

### PSTN (telephone) Installation

Attach one end of a modular RJ-11 cable to the port labeled “PSTN” at the rear of the *ProTekTor+*. Attach the other end to any standard telephone network jack. Remember that some PBX systems may be incompatible with the *ProTekTor+* due to their proprietary status signaling protocols.

### DC Power Cable Installation

Attach the supplied 15-ft DC power cable to the 12 VDC port labeled “12VDC” at the rear of the *ProTekTor+*. (The **red** lead is positive.) *Always externally fuse the 12 VDC supply with a 1-A fuse.* If desired, an optional “wall-wart” power supply may be used for operation on 120 VAC mains.

### Interconnection Options

#### Type 66 Punch Block

An optional 50-row connectorized punch block with a three-foot pigtail terminated with an RJ-21M (Ortronics part # OR-804025PX025-5TH) connector is available. This option reduces the labor required and may ease installation.

The Type 66 punch block has four columns of punch-down stakes, divided into two pairs of circuits, connected with bridging clips. The bridging clips can be removed to isolate any circuit to or from the *ProTekTor+*. The left-most column of the punch block (oriented with the 50-pin connector in the lower right) is reserved for external connections to the *ProTekTor+*. The center two columns are reserved for the bridging clips used to connect external signals to the *ProTekTor+*. The right-most column is reserved for connections to the 25-pair interface cable from the *ProTekTor+* interface connector attached to the punch block.

#### Double Terminated Telco Cable

An optional 25-pair Telco cable terminated at each end with RJ-21M connectors is available. A 25-pair Telco cable terminated at one end with RJ-21M connector is generally supplied with the full build *ProTekTor+*.

### Wall Mount AC Power Supply

An optional 115 VAC wall mount transformer may be connected as the primary *ProTekTor+* power source. Plug the molded connector of the wall transformer cord into port labeled “12 VDC” at the rear of the *ProTekTor+*. Plug the wall transformer into a suitable three prong grounded 120 VAC receptacle. Remember that the *ProTekTor+* will shut down if commercial AC power is lost. Applications requiring continued operation with failed AC mains should power the *ProTekTor+* with a 12 VDC battery bank or AC UPS. See the voltage to wattage conversion tables in Appendix A, p.37.

## Optional Equipment Installation

(in-shop)

See “Voltage to Wattage Conversion Tables” Appendix A, p.37).

See “Inputs,” p. 20-22.

### Tower Light Sensor

An optional tower light sensor is an AC current sensing loop through which the supply line to the lights must be passed. Although available in a range of values, 10 and 15 ampere sensors are most commonly used. If a common feed is used, connecting the sensor to an analog input and programming (via the “Inputs” screen) for voltage allows the technician to determine if all lights are *out* or if it is only a single lamp. The sensors can also be used for general purpose AC current measuring.

### Temperature Sensor

An optional external temperature sensor may be connected to an analog configured input of your choice. This sensor requires 12 V, which may be supplied by the *ProTekTor+* at pin 25 of the interface connector. Negative temperatures are designated with a minus sign preceding the value while positive temperatures are implied.

See “Inputs,” p. 20-22.

The user specifies that the temperature sensor is being used on an input by programming (via the “Inputs” screen) the limits of that input with the F token. Use of the F token specifies that the results be displayed in degrees Fahrenheit.

### Telewave™ RF Power Sensor

An optional Telewave™ bidirectional RF power sensors are used for measuring forward and reflected RF power. Three models are available to provide for various frequency ranges as seen in the table below. Each model measures up to 1000 watts. Call the factory regarding additional sensor needs.

| Model     | Frequency Range |
|-----------|-----------------|
| PM-2A-50  | 30 to 88 MHz    |
| PM-2A-300 | 118 to 512 MHz  |
| PM-2A-900 | 806 to 960 MHz  |

The Telewave™ sensor is installed in the transmission line at the point where power is to be measured. This may be the output of the transmitter or the output of any isolators or resonant cavities. It is strongly recommended that shielded cable is used when wiring the sensors to reduce jitter or instability caused by induced RF interference. Phono plugs are also included with each sensor.

The Telewave™ sensor requires that the supporting input be configured as either a 5 VDC or 50 VDC input. The 5 VDC configured input will display RF wattage values of up to 400 watts. The 50 VDC configured input will display RF wattage values of up to 999 watts.

# Post Installation Adjustments

## RF Power Sensor Calibration

Each RF power sensor must be calibrated. Program two analog configured inputs to measure station forward and reflected power. Insert a wattmeter in line with the power sensor. With the station keyed, adjust the forward power potentiometer located on the sensor to obtain the same reading as the wattmeter. Dekey the station and reverse the coax cables connected to the sensor (not the sensor phono plugs) and key the station. Adjust the sensor reflected power potentiometer so that the value registered by the *ProTekTor+* matches the wattmeter reading. Refer to the **Operation** section of this manual for use of the Global Status screen to read the normal level value displayed. Dekey the station and restore the coax cables to normal. This completes the sensor calibration.

See "Global Status" screen field descriptions, p.33.

## Local VDT Set Up

The local VDT port is configured as Data Communication Equipment (DCE) and should work with the same cable and terminal configuration used with a modem.

Set the communications port parameters of the terminal or terminal emulation to match those of the *ProTekTor+*:

- Bits per second: 9600 (for initial programming)
- Start Bit: 1
- Data Bits: 8
- Stop Bit: 1
- Parity: None
- Flow control: XON-XOFF

The physical pin-out of the RS-232C connector for DCE configuration is as

| Signal Name               | Pin # | DCE                 |
|---------------------------|-------|---------------------|
| Data Set Ready (DSR)      | 6     | Unused              |
| Transmit Data (TD)        | 3     | Input               |
| Receive Data (RD)         | 2     | Output              |
| Clear To Send (CTS)       | 8     | Output              |
| Signal Ground             | 5     |                     |
| Data Carrier Detect (DCD) | 1     | Output <sup>1</sup> |
| Data Terminal Ready (DTR) | 4     | Unused              |
| Ready to Send (RTS)       | 7     | Input               |

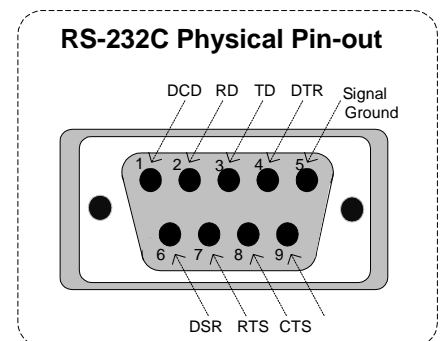

follows:

<sup>1</sup> DCD is permanently asserted and is provided only for compatibility with terminals that require it.



# 3

## Programming

### Connecting (Overview)

With power, phone line, interface connector, and local VDT connected you are ready to begin the initial programming! While the local port will autobaud to rates of 4800 bps to 38400 bps, 9600 bps is recommended during initial programming. Logging in at any other speed will result in the message, “testing flash (press escape now to enter debug mode)” being displayed as garbage characters due to speed mismatch. However, since this message is displayed only at power up, any supported speed may be used during normal operation.

Log into the *ProTekTor+*, by first typing a carriage return or two so that the local port can autobaud to your connection speed. When the system has autobauded successfully, it will display “ENTER YOUR PASSWORD PLEASE:” and await the password entry on the next line. The appropriate four- to eight-digit password should be entered at the cursor followed by <return>. A valid password will prompt the system to determine the access rights of the person logging in and the appropriate initial screen will appear. The default full access password used during initial commissioning is 1111 (four ones). The default Observer (read-only) password is 0000 (four zeros).

If no matches are found, “WRONG” is displayed, the attempt is logged as “Invalid terminal password” in the *History*, and the prompt “ENTER YOUR PASSWORD PLEASE:” will be given again. After three incorrect password entries, the connection will be terminated. The incorrect password is recorded in the log, but censored to those with read-only passwords. Resume the log-in procedure when the correct password is ascertained.

Upon successful log-in, the user log-in Password and User Name are logged in the *History*. The *Global Status* screen is automatically displayed if any alerts are in progress at log-in, otherwise the *Main Menu* is displayed. If taken to the *Global Status* screen, the user may access the *Main Menu* by entering <escape>.

Log-out is achieved using the TC (terminate connection) command on the *Main Menu*. Upon receiving a TC command, the screen is cleared, the user is logged out, and an entry indicating user log-out is written to the *History*. This process occurs only if there are no alerts in progress. If alerts are in progress when the TC command is issued, the *Global Status* is displayed, and the prompt “ALERTS IN PROGRESS! EXIT ANYWAY? (Y/N)” appears at the bottom of the screen. Entering “Y” clears the screen, saves the configuration, and logs out the user as described above. Entering “N” returns the user to the *Global Status* screen to acknowledge the alerts. If the user made any changes to the configuration during the session, the configuration will automatically be saved to flash memory and the following messages will be displayed: “Saving modified configuration to flash memory.” and “Configuration saved. Logging out...” The fact that the configuration was written to memory will be logged in the *History*.

### Logging In (Overview)

Default Password: 1111

### Logging Out (Overview)

If the operator fails to terminate a local VDT or modem connection, the port will remain active until the idle time-out limit is reached (1-99 minutes as determined by user programming). During this time the system could be locally accessed without a password.

If the operator leaves the connection open without any interaction, the *ProTekTor+* will drop the connection when the idle time limit is reached. In this case, the user is automatically logged out, and the message "Idle time limit exceeded. Goodbye." is displayed. If a user was logged in when the idle time-out occurred, and the user made changes to the configuration, the configuration will automatically be saved to flash memory and the user log-out will be added to the *History*. Unlike normal log-outs, the *Global Status* will not be displayed if alerts are in progress when an idle time-out occurs. Remember that the default time out period is three minutes, but may be programmed for up to 99 minutes.

## Screen Navigation Commands

(Overview)

All screens share some or all of the navigational commands indicated below:

|                  |  |
|------------------|--|
| RETURN=next page | Entering <return> will invoke the next page on those screens that flow over multiple pages (such as the <i>History</i> ).  |
| B=previous page  | Entering B <return> will return the user to the previous page on those screens that flow over multiple pages. (This command is not available on the first page of multipage screens.) Entering <escape> will return the user to the initial (parent) page. |
| ESCAPE=previous  | Entering <escape> will return the cursor to command mode if the cursor is in an editable field or if the screen is already awaiting a command return to the parent screen.   |
| #/LETTER         | Entering the desired screen number/letter (menu item) followed by <return> will evoke most screens or command sequences. The command line prompt will indicate the available choices.  |
| Z=repaint        | Entering Z <return> repaints the currently accessed screen. (The repaint function may be required due to a communications hiccup.)   |

Note that the current cursor location is indicated by a blinking underscore ( `_` ) symbol.

# System Initialization

## Password screen

This screen is automatically displayed during the first log-in procedure. Enter the default full access password (1111), which will be echoed back as astericks.

```
ENTER YOUR PASSWORD PLEASE:  
****
```

## Main Menu

Once logged in successfully the Main Menu will appear as seen below. Select the appropriate menu for your use, but if logging in for the first time, the user should select "1. Site Configuration" and review the programming for acceptability. View the "Site Configuration Screens Overview" for a description of allowable programming. (see next page)

```
Site Name: ProTekTor+                               Time: 17:38:39  
Site ID: 1234                                       Date: 04/26/00  
  
ProTekTor+ v1.3  
Main Menu  
  
1      .Site Configuration  
2      .Commands  
3      .User Passwords  
4      .History  
5      .Global Status  
TC     .Terminate call
```

Enter desired screen number or Z to repaint

## Site Configuration

The Site Configuration menu is where most of the *ProTekTor+* personality is set and where all of the required initial programming is conducted. Enter menu item 1<return> to access the first programmable screen.

|                       |                            |
|-----------------------|----------------------------|
| Site Name: ProTekTor+ | Time: 17:38:39             |
| Site ID: 1234         | Date: 04/26/00             |
| Site Configuration    |                            |
| 1                     | .Site Information          |
| 2                     | .System Parameters         |
| 3                     | .User Passwords            |
| 4                     | .Input-Alert Schedule List |
| 5                     | .Alert Call Parameters     |
| 6                     | .Status Call Parameters    |
| 7                     | .Inputs                    |
| 8                     | .Relays                    |
| 9                     | .Input Activity Tests      |

ESCAPE key = previous, Z = repaint

**NOTE:**  
System Configuration Worksheets are provide in Appendix B. Use these worksheets to record each programmed element.

### Site Configuration Screens Overview

1. Site Information allows for programming of the time and date in addition to your *ProTekTor+*s' unique identifiers.
2. System Parameters allows for designation of the TAPP logging and alert calls as enabled or disabled.
3. User Passwords allows for programming of up to six observer (read-only) and six technician (read/write) passwords to be used to access the *ProTekTor+*.
4. Input-Alert Schedule List allows for programming of up to five unique schedules for system use.
5. Alert Call Parameters allows for the programming of those telephone numbers to be called by the Alert Call task. The scheduling and frequency of the Alert Calls are also programmed here.
6. Status Call Parameters allows for the programming of the telephone number to be called by the Status Call task and allows the technician to set the frequency at which such calls are made.
7. Inputs allows for programming of the software configuration for all inputs. While the type and scaling of each input is read by the system at power up, the user must still enable each input, and specify operational parameters, including the units to be measured, (i.e., watts (W), volts (V), temp (C or F), etc.) .
8. Relays allows for programming of the duration for which the relay will be active in addition to type and description.
9. Input Activity allows for configuration of the conditions under which a monitored input will generate an alarm based upon the activity sensed on that input.

## Site Information

The Site Information screen allows the user to program site identification, date, and time. Enter the appropriate information in each field following the parameter limitations. A screen simulation and parameter descriptions follow. Enter parameter line number (1-4) to modify.

|                       |                |
|-----------------------|----------------|
| Site Name: ProTekTor+ | Time: 17:38:39 |
| Site ID: 1234         | Date: 04/26/00 |

Site Information

|   |             |            |
|---|-------------|------------|
| 1 | .Site ID:   | 1234       |
| 2 | .Site name: | ProTekTor+ |
| 3 | .Date:      | 04/26/00   |
| 4 | .Time:      | 17:45:38   |

1-4 = modify parameter  
ESCAPE key = previous, Z = repaint

### Site ID

This parameter will accept any four-digit number. It is suggested that this number be unique. The user may find it convenient to use the *ProTekTor+* serial number to ensure uniqueness and to facilitate asset tracking. The Site ID will be used to identify the site in all alert and status call messages.

Record programmed parameters on the "Site Information Worksheet" Appendix B, p.47.

### Site Name

This parameter will accept any alphanumeric string of up to 16 characters. This string will be used to identify the site in all alert and status call message.

### Date

This parameter should be set to the current date using the format MM/DD/YY. When monitors are installed in several time zones it may be advantageous to use Universal Coordinated Time (UTC) to reduce the potential for confusion.

### Time

This parameter should be set to the current time using the format HH:MM:SS in the 24-hour format. Again, when monitors are installed in several time zones it may be advantageous to use Universal Coordinated Time (UTC) to reduce the potential for confusion. It is not necessary to enter the seconds unless desired, The *ProTekTor+* clock accepts the time when the <return> key is pressed.

One or more modifications to this screen are logged once as:

"Site Configuration modified by "<LOG IN NAME>"."

**Next Step:**  
Return to the Site Configuration menu by entering <escape> and then select item 2.

## System Parameters

The System Parameters screen allows modification of two parameters that will generally remain in their default states. A screen simulation and command descriptions follow. Enter command line number (1-2) to modify.

```
Site Name: ProTekTor+                               Time: 17:38:39
Site ID: 1234                                       Date: 04/26/00

                               System Parameters

1      .Enable detailed TAPP log messages: N
2      .Enable alert calls: Y

1-2 = modify parameter
ESCAPE key = previous, Z = repaint
```

Record programmed parameters on the "System Parameters Worksheet" Appendix B, p.47.

### Enable detailed TAPP log messages

This command facilitates troubleshooting when connections to the TAPP compliant terminal are difficult. All status messages from the TAPP terminal are logged to the local history file and may be examined in case of difficulty. Any difficulty connecting to a terminal is generally due to the terminal, its modem banks, or the PSTN. Entering "Y" will enable log messages and entering "N" will disable log messages. You may toggle between entries by pressing the space bar. *Factory default for this parameter is disabled "N."*

### Enable alert calls

This command may be useful if the monitored equipment is being serviced and would otherwise generate numerous false alarms. A less drastic alternative is to disable only the input or inputs that will be in alarm state for extended periods. Entering "Y" will enable alert calls and entering "N" will disable alert calls. You may toggle between entries by pressing the space bar. *Factory default for this parameter is enabled "Y."*

One or more modifications to this screen are logged once as:

"Site Configuration modified by "<LOG IN NAME>"."

**Next Step:**  
Return to the Site Configuration menu by entering <escape> and then select item 3.

## User Passwords

The User Passwords screen allows access passwords to be entered in the *ProTekTor+* memory. Two classes of passwords are supported: limited access (read-only) passwords--observer, which allow oversight, but no control or configuration of the *ProTekTor+*; and full access (read/write) passwords-technician, which give the user complete access to the monitor. The User Passwords screen is not visible to those holding limited access passwords. The passwords may be used to track who accesses the *ProTekTor+* and what if any commands they send to the unit. A minimum of one full access password must be programmed. For security purposes the default password of 1111 should be overwritten.

This screen may also be accessed directly from the Main Menu. A screen simulation and field descriptions follow. Enter parameter line number (1-12) to modify.

```
Site Name: ProTekTor+                               Time: 17:38:39
Site ID: 1234                                       Date: 04/26/00

                                User Passwords

Limited Access (Read-only) Passwords
  Name                               Password
1   .Default observer                0000
2   .R/O 2 user name                 r/o2
3   .R/O 3 user name                 r/o3
4   .R/O 4 user name                 r/o4
5   .R/O 5 user name                 r/o5
6   .R/O 6 user name                 r/o6
Full Access (Read/write) Passwords
  Name                               Password
7   .Default technician 1111
8   .Full access user 8 88888888
9   .Full access user 9 3
10  .
11  .
12  .

ESCAPE key = previous, Z = repaint, D = delete, 1-12 = modify field
```

### Name

This field allows for programming of user names up to 20 characters in length. It is suggested that each password holder's name be programmed to facilitate easy tracking of user actions. Any action taken will generate a local history entry that includes name and password. While programming, if the cursor is in an empty user name field, hitting <tab> or <return> moves the cursor to the next field. However, entry into the password field is not allowed if the name field is empty. This prevents an unnamed user from accessing the system.

Record programmed parameters on the "User Passwords Worksheet" Appendix B, p.48.

### Password

This field allows for programming of the four- to eight-character user passwords. Highest security is maintained by using eight characters. The password is case-sensitive. Each person given access rights must be assigned a password. This password will be used by the system to determine who is logging in and at what level of access that person can operate. Any action taken will generate a local history entry including name and password. Passwords may be duplicated if required, but logging of user interaction with the *ProTekTor+* will be less precise.

**Note:** Remember to delete the 1111 default password.

One or more modifications to this screen are logged once as:

"User # added by "LOG ON NAME"."

(1-12) ↑

**Next Step:**  
Return to the Site  
Configuration menu and  
select item 4.

## Input-Alert Schedule List

The Input-Alert Schedule List allows for the programming of up to five schedules that may be used to enable inputs during specific time periods. The start and end times may be indicated with seconds precision. Each schedule may be designated as active for any one (or more) of the seven days of the week. A screen simulation and parameter descriptions follow. Enter schedule number (1-5) to modify.

|   |                |          |         |
|---|----------------|----------|---------|
| Site Name: ProTekTor+                                       | Time: 17:38:39 |          |         |
| Site ID: 1234   | Date: 04/26/00 |          |         |
| Input-Alert Schedule List                                   |                |          |         |
| Schedule  | Start Time     | End Time | Days    |
| 1   | .13:34:56      | 24:00:00 | MT H    |
| 2   | .00:00:00      | 24:00:00 | MTWHFSU |
| 3   | .18:20:00      | 18:30:00 | U       |
| 4   | .18:17:00      | 18:18:00 | U       |
| 5   | .00:00:00      | 00:00:00 |         |
| 1-5 = modify schedule<br>ESCAPE key = previous, Z = repaint |                |          |         |

Record programmed parameters on the "Input-Alert Schedule List Worksheet" Appendix B, p.48.

### Schedule

This field displays the schedule number from 1 to 5.

### Start Time

This parameter allows for programming of the schedule starting time. Enter time in 24-hour format.

### End Time

This parameter allows for programming of the schedule starting time. Enter time in 24-hour format.

### Days

This parameter allows for programming of the days for which the schedule is to be scheduled. Enter individual days abbreviated as MTWHFSU. Notice that Thursday is represented by H and Sunday is represented by U. All other days are represented by their first letter.

One or more modifications to this screen are logged once as:

"Site Configuration modified by "LOG IN NAME"."

### **Next Step:**

*Return to the Site Configuration menu by entering <escape> and then select item 5.*

## Alert Call Parameters

The Alert Call Parameters screen allows entry of up to eight telephone numbers to be called by the *ProTekTor+* during a major alarm. For a detailed description of alert call message structure sent to both numeric-only and alphanumeric pagers, refer to Appendix A p.46. A screen simulation and parameter descriptions follow. Enter parameter line number (1-8) or the first letter of additional parameters (C,A,I, or S) to modify.

|   |                |  |      |              |              |
|---|----------------|--|------|--------------|--------------|
| Site Name: ProTekTor+                                 | Time: 17:38:39 |  |      |              |              |
| Site ID: 1234   | Date: 04/26/00 |  |      |              |              |
| Alert Call Parameters                                 |                |  |      |              |              |
| Telephone Number List                                 |                |  |      |              |              |
| #   | Type           | Schedule                                   | Qual | Modem Number | Pager Number |
| 1   | .MODEM         | 0  |      | 5551234      |              |
| 2   | .PAGER         | 0  |      | 5551213      | 1234567      |
| 3   | .MODEM         | 0  |      |              |              |
| 4   | .MODEM         | 0  |      |              |              |
| 5   | .MODEM         | 0  |      |              |              |
| 6   | .MODEM         | 0  |      |              |              |
| 7   | .MODEM         | 0  |      |              |              |
| 8   | .MODEM         | 0  |      |              |              |
| Parameters  |                |  |      |              |              |
| Call sequence: 1                                      |                |  |      |              |              |
| Attempts per number (1-255): 255                      |                | Interval between calls (1-255 minutes): 10 |      |              |              |
| Sequence repetitions (1-255): 5                       |                |  |      |              |              |
| 1-8,C,A,I,S = modify parameter                        |                |  |      |              |              |
| ESCAPE key = previous, Z = repaint, L = schedule list |                |  |      |              |              |

### Type

This parameter allows the technician to program whether the alert call will be sent to a modem or pager. Hitting the space bar or entering "M" or "P" (either lower or uppercase) may be used to toggle between MODEM and PAGER types.

*Record programmed parameters on the "Alert Call Parameters Worksheet" Appendix B, p.49.*

### Schedule Qual

This parameter allows for programming which, if any, schedule (1-5 programmed on the previous screen) determines the times at which this number may be called by the *ProTekTor+*. Any number scheduled within an inactive schedule will be omitted from the calling sequence. If a single entry call sequence is not scheduled to be active when an alarm occurs, no alert call will be sent. An entry of zero means no qualification.

### Modem Number

This parameter allows for programming of the modem number to be called by the *ProTekTor+*. The Modem Number field can contain up to 40 characters. Each character entered must be a digit (0-9), one of the special characters (\*, #, a-d, p, t, !, w, @, &, <comma>, ^, -, <space>, and > as defined in the table located in Appendix A). Any other character entered in the field makes the entry invalid and the user must re-enter the entire number. Entering a blank clears the field.

See "Modem Dialing String Special Characters" table in Appendix A, p. 44.

After entering a number in the Modem Number field, the cursor moves to the next telephone number. If the type of a number was PAGER, but the user changes the type to MODEM, the Pager Number field will be cleared both on-screen and in memory.

### Pager Number

This parameter allows for programming of the pager number to receive the alert call message sent by the paging terminal. The `Pager Number` field can contain up to 16 characters. No error checking is performed since TAPP allows any character. Entering all blanks clears the field.

If the type is `PAGER`, the user is allowed to enter a number both in the `Modem Number` and `Pager Number` fields. Note that the user is not allowed to enter anything in the `Pager Number` field if the type is set to `MODEM`.

### Call Sequence

This parameter allows for programming of the numbers to be called during an alert. The list may contain up to eight entries from the `Telephone Numbers List` column and may include repeated numbers. Valid entries are numbers 1-8. Delimiting the numbers is not required, but any number of blanks or a single comma may be used between digits. Entering a zero only or all blanks clears the call sequence. At present, this field supports a single calling sequence, but additional calling sequences may be available for special uses.

### Attempts per number

This parameter allows for programming of the number of times the telephone or pager number is dialed before moving to the next number in the list. Any value from 1 to 255 is accepted. Please notice that an attempt may not be successful due to busy signals or other PSTN problems.

### Interval between calls

This parameter allows for programming the period (in minutes) between outbound alert call attempts. Any number from 1 to 255 minutes is accepted, though a value under five minutes can make it difficult to access the *ProTekTor+* if outbound alert calls are in progress.

### Sequence repetitions

This parameter allows for programming the number of complete sequences repeated before the sequence is terminated. Any number from 1 to 255 is accepted.

One or more modifications while in this screen are logged once as:

“Alert Call Parameters Modified by “LOG IN NAME”.”

#### **Next Step:**

*Return to the Site Configuration menu by entering <escape> and then select item 6.*

## Status Call Parameters

The Status Call Parameters screen allows for entry of the phone number to be called, the date/time at which the call will be placed, and the interval between calls. The telephone number list entered in the Alert Call Parameters screen is displayed on the first half of this screen in read-only format for reference purposes. A screen simulation and parameter descriptions follow. Enter first letter of parameter (N,D, or I) to modify.

```
Site Name: ProTekTor+                               Time: 17:38:39
Site ID: 1234                                       Date: 04/26/00

                                Status Call Parameters

Telephone Number List
#      Type      Schedule Qual Modem Number Pager Number
1      MODEM     0                               101
2      PAGER     0                               1234567
3      MODEM     0
4      MODEM     0
5      MODEM     0
6      MODEM     0
7      MODEM     0
8      MODEM     0

Parameters

Number for status call (1-8, 0 = no status call): 1
Date/time for next status call (MM/DD/YY HH:MM:SS): 04/27/00 15:54:00
Interval in hours between status calls (1-255): 24

N,D,I = modify parameter
ESCAPE key = previous, Z = repaint, L = schedule list
```

### Number for status call

This parameter allows for programming of the status call number and accepts any digit from 0 to 8. Entry of a zero indicates that no status call will be made. The number must be one of those programmed in the Alert Call Parameters screen.

Record programmed parameters on the "Status Call Parameters Worksheet" Appendix B, p.50.

### Date/time for next status call

This parameter allows for programming of the status call time in 24-hour (HH:MM:SS) format and date in MM/DD/YY format. Enter both the time and date delimited by colons and slashes respectively, as seen above. Separate time and date by a space. Entry of seconds is optional.

### Interval in hours between status calls

This parameter defines the length of time in hours between each status report. An interval from 1 to 255 hours can be specified. If a weekly report on a specific day is desired, the status call must be programmed on that day. The status call also uses the attempts per number as programmed on the Alert Call Parameters screen.

See previous page.

One or more modifications to this screen are logged once as:

"Status call parameters modified by "LOG IN NAME"."

**Next Step:**  
Return to the Site Configuration menu by entering <escape> and then select item 7.

## Inputs

The Inputs screen allows for programming of various operational parameters for each of the eight inputs. A screen simulation and parameter descriptions follow. Enter line number (1-8) to modify.

| Site Name: ProTekTor+ |               | Time: 17:38:39  |        |          |          |      |        |       |
|-----------------------|---------------|-----------------|--------|----------|----------|------|--------|-------|
| Site ID: 1234         |               | Date: 04/26/00  |        |          |          |      |        |       |
| Inputs                |               |                 |        |          |          |      |        |       |
| #                     | Description   | Normal Level    | Qlf By | Time Dly | Alm Type | Enab | Relays | Sched |
| 1.                    | Input 1 Label | CLOSED          | 0      | 0        | MAJ      | Y    | 1      | 0     |
| 2.                    | Input 2 Label | CLOSED          | 0      | 0        | MAJ      | Y    | 2,3,5  | 0     |
| 3.                    | Input 3 Label | OPEN            | 0      | 0        | MIN      | N    | 3      | 3     |
| 4.                    | Input 4 Label | CLOSED          | 0      | 5        | QUAL     | N    | 4      | 4     |
| 5.                    | Input 5 Label | 00.0V to -04.9V | 0      | 0        | MAJ      | N    | 1      | 0     |
| 6.                    | Input 6 Label | 00.0V to +50.0V | 0      | 0        | QUAL     | N    |        | 0     |
| 7.                    | Input 7 Label | 00.0V to -50.0V | 0      | 0        | QUAL     | N    |        | 0     |
| 8.                    | Input 8 Label | 00.0V to +50.0V | 0      | 0        | RTN      | N    |        | 0     |

1-8 = modify input parameters  
 ESCAPE key = previous, Z = repaint, S = Schedule List

**Record programmed parameters on the "Inputs Worksheet" Appendix B, p.50.**

**Description**  
 This parameter allows for programming of a 16 character (maximum) alphanumeric description of the input. Since this string will be reported in any text alarm, the user may wish to describe the failure rather than the input.

**Normal Level**  
 This parameter allows for programming of the specific input's Normal Level. Programming options vary depending on how the input has been configured. The configuration plugs used for input conditioning inform the ProTekTor+ whether they are digital or analog and the field is formatted appropriately. Formatting options are as follows:

*Digital Mode--Contact Closure*

In the contact closure mode the Normal Level field indicates either CLOSED or OPEN. This terminology refers to a device that functions as a contact closure. The actual nature of the input conditioning may vary depending upon the characteristic of the equipment being monitored. Generally, CLOSED indicates a shorted input, while OPEN indicates a floating input. The contact closure configuration supplies an internal pull-up voltage on the input.

### *Analog Mode*

In the analog mode the `Normal Level` field indicates a range with a lower and upper limit. In this case, the lower limit is either the least positive or the most negative set point. (Example: with set points of -50 VDC and -46 VDC, -50 V would be the lower limit and -46 V would be the upper limit. If measuring a +12 VDC supply, 11.5 V would be set as the lower limit and 14.2 V would be set as the upper limit.) The initial default level will be zero to full scale of the appropriate polarity, i.e., a -50 VDC configured input would have default level of 00.0 V to -50.0 V. It is possible, however, for a 50 VDC configured input to read and respond appropriately to +50 VDC to -25.0 VDC, a -50 VDC configured input to read and respond appropriately to +25.0 VDC to -50 VDC, for a 5 VDC configured input to read and respond appropriately to -2.5 VDC to +5.0 VDC, etc. When an input is designated as an analog type there are actually two fields available, one on either side of the “`±`”, which will be skipped over by the cursor.

### `Qlf By`

This parameter allows the qualification of any input by any other input (1-8). The qualifying input must be *active* (outside its normal range if analog, or at its active level if digital) before the input being qualified can be *active*. Thus, even though the qualified input is outside its range it will not be *active* itself until the qualifier is also *active*. No entry means this input is not qualified. An incorrect entry can be cleared by entering two spaces (two space bars) or zero followed by `<return>`.

A common use of the qualifier is the monitoring of a transmitter keyline. In this situation, one channel is configured as an analog channel indicating watts. A second channel, generally configured as a digital channel, monitors the PTT line of the transmitter and qualifies the analog channel monitoring the RF power sensor. The qualification allows airtime to be recorded and prevents falsing of intermittent duty transmitters.

### `Time Dly`

This parameter allows qualification of any input by a time delay in seconds. The input must remain outside its specified range continuously for longer than the specified “time delay” before becoming *active*. No entry is the same as 0.0 seconds. Valid values range from 1 to 255 seconds.

### `Alm Type`

This parameter allows for designation of each input as one of four alarm types. Alarm types determine what action is taken by the *ProTekTor+* when that input is *active*. Any input may qualify another input(s) regardless of its alarm type. However, if an input is meant only to qualify another input, and is not required to make a log entry or generate an alarm independently, then it should be programmed as a qualifier (`QUAL`) alarm type. The four alarm types and their response-to-alarm characteristics are as described on the following page.

|                  |   |
|------------------|---|
| <code>MIN</code> | A minor alarm will be logged in the <code>History</code> and the Alarm front panel indicator will light. The input may qualify other inputs. However, an alert call sequence will not be generated from this alarm. |
|------------------|---|

|      |  |
|------|--|
| MAJ  | A major alarm will be logged in the <code>History</code> and the Alarm front panel indicator will light. The alert call sequence is also initiated, if so programmed. The input remains in the alarm state until its level returns to within the programmed limits or the qualifier (if programmed) goes <i>inactive</i> . |
| RTN  | This alarm sends a return-to-normal alert call sequence when the input returns to normal.  |
| QUAL | This input, when <i>active</i> , will be used only to qualify other inputs. While it will not generate an alarm, it may be used to control relays. The qualifier may be thought of as a Boolean AND command in that both the input qualified and the qualifier must be <i>active</i> for an alert to be generated.         |

#### Enab

This parameter allows for the enabling “Y” or disabling “N” of any input. A disabled input will not cause an alarm, turn *on* a controlled relay, or qualify another input if it is a qualifier. When an input or input activity test is disabled, the *ProTekTor+* resets its status to *normal*. When a user input is disabled, its activity test is also disabled. The qualified input will remain in *normal* state. If the input is *active* when it is subsequently enabled, it must go through a full qualification cycle before the *ProTekTor+* will put it in the active state.

See “Relays” screen for programming, next page.

See “Commands menu” in the “Operations” section (ch 4) of this manual, pp.31-32.

#### Relays

This parameter is used to enter any relay outputs (1-4) that the specific input will control. Up to four relay output numbers can be entered (optionally delimited by a space, comma, period, or slash). The `Relays` screen shows all controlled relays. If a relay output is *on*, it will stay *on* until all controlling inputs leave their active state or until the inputs are disabled (unless latched). Latched relays must be released by the Release Relay command. Relays programmed as momentary will automatically be reset by the system.

See “Input -Alert Schedule List,” p.16.

#### Sched

This parameter provides for designation of which, if any, schedule (1-5 as programmed in the `Input-Alert Schedule List`) enables the specific input. The current time and date must match the specified schedule before the input can go active. An entry of zero indicates no schedule.

Any modifications to this screen are logged once as:  
“Site Configuration modified by “LOG IN NAME”.”

**Next Step:**  
Return to the Site Configuration menu by entering <escape> and select item 8.

## Relays

The Relays screen allows the relay description and characteristics to be programmed. Any mapping of the relays to inputs or activity tests is performed on those screens (respectively, menu items 7 and 9 of the Site Configuration menu). A screen simulation and parameter descriptions follow. Enter line number (1-4) to modify.

| Site Name: ProTekTor+ | Time: 17:38:39 |            |      |                       |                               |
|-----------------------|----------------|------------|------|-----------------------|-------------------------------|
| Site ID: 1234         | Date: 04/26/00 |            |      |                       |                               |
| Relays                |                |            |      |                       |                               |
| #                     | Description    | Type       | Time | Controlling<br>Inputs | Controlling<br>Activity Tests |
| 1                     | Relay 1        | LATCHED    | 1    | 1,5                   | 1                             |
| 2                     | Relay 2        | NORMAL OFF | 1    | 2                     |                               |
| 3                     | Relay 3        | MOMENTARY  | 5    | 3                     | 1                             |
| 4                     | Relay 4        | NORMAL     | 2    | 4                     |                               |

1-4 = modify relay  
ESCAPE key = previous, Z = repaint

### Description

This parameter allows the full access user to enter a description of up to 20 characters that will be used to identify the relay during alert calls and History logging.

Record programmed parameters on the "Relays Worksheet" Appendix B, p,51.

### Type

This parameter allows the user to program any relay to function as a normal, latching, or momentary type. This programming determines how the relay will respond to any command given either by the user or the system.

**Normal:** this type relay will activate by input state and will deactivate by a return-to-normal command.

**Latching:** this type relay, when commanded on by the operating system as a result of an input state, will remain activated, regardless of any return-to-normal by that input and must be released by manual command.

**Momentary:** relay will remain *on* only for the duration specified in its associated Time field. (See next parameter description.)

Relay commands are processed in the following order: forced, system command (with type classification overriding any contrary command), and lastly, the manual strobe command. The Time value for a relay must be specified for the strobe command to work. If the relay has been designated as a momentary type it will strobe for the duration specified for the momentary operation.

### Time

This parameter allows the user to program the length of time a relay will be active if programmed as a momentary type, or the length of time the relay will be activated if given the Strobe command. This parameter accepts entry of 0-99 seconds and no units token is accepted. A momentary relay may be strobed manually, but will use the same *on* duration previously specified for the momentary operation. Users may wish to also program normal relays with a time value in case a strobe operation is required in the future. Latching relays may be strobed for the period specified in their Time field.

### Controlling Inputs

This field displays the controlling inputs as programmed in the Relays filed on the Inputs screen. (See previous page.)

### Controlling Activity Tests

This field displays the relay output numbers that this input test will control in its active state. This field is read-only on this page, but is programmable in the Relay filed on the Input Activity Tests screen. (See next page.)

One or more modifications to this screen are logged once as:

“Site Configuration modified by “LOG IN NAME”.”

**Next Step:**  
*Return to the Site Configuration menu by entering <escape> and then select item 9.*

## Input Activity Tests

The `Input Activity Tests` screen allows users to configure the conditions under which a monitored input will generate an alarm based upon the activity sensed on that input (rather than the state of the input). As an example, this may be used to alert the technical staff if a piece of equipment is stuck *on* or has failed to operate for a period known to indicate a failure. The `Input Activity` test will attempt to force activity by dialing a telephone number or activating a relay as specified in the `Force Activity` field. The system will dial the telephone number supplied by the user and hang up upon connection. This is the functional equivalent of a tone-only page. Though a pager need not actually be used, the cap code must be valid if this facility is used to force a page through a paging terminal.

If a relay is programmed to force activity, that relay will be actuated throughout the wait period specified in the `Wait Time` field. Since this field can be set to a range from one second to 255 days, ensure that the equipment being commanded can handle whatever period is programmed here. If the programmed `Wait Time` is set to “none” or “0” there will be no attempt to force activity either by relay actuation or dialing of the telephone number. A screen simulation and parameter descriptions follow. Enter line number (1-8) to modify.

| Site Name: ProTekTor+            |               | Time:          |                      |           |             |          |      |       |
|----------------------------------|---------------|----------------|----------------------|-----------|-------------|----------|------|-------|
| 17:38:39                         |               |                |                      |           |             |          |      |       |
| Site ID: 1234                    |               | Date: 04/26/00 |                      |           |             |          |      |       |
| Input Activity Tests             |               |                |                      |           |             |          |      |       |
| #                                | Description   | Inact Time     | Force Activity       | Wait Time | Maxact Time | Alm Type | Enab | Relay |
| 1.                               | Input 1 label | 99d            | R1                   | 1m        | 10h         | QUAL     | N    | 1,2,3 |
| 2.                               | Input 2 label | 601m           | 12345678901234567890 | 100m      | 1m          | QUAL     | N    |       |
| 3.                               | Input 3 label | 23s            |                      | NONE      | NONE        | QUAL     | N    |       |
| 4.                               | Input 4 label | NONE           | R2                   | 1s        | 90s         | QUAL     | N    |       |
| 5.                               | Input 5 label | NONE           |                      | NONE      | NONE        | QUAL     | N    |       |
| 6.                               | Input 6 label | NONE           |                      | NONE      | NONE        | QUAL     | N    |       |
| 7.                               | Input 7 label | NONE           |                      | NONE      | NONE        | QUAL     | N    |       |
| 8.                               | Input 8 label | NONE           |                      | NONE      | NONE        | QUAL     | N    |       |
| 1-8 = modify activity parameters |               |                |                      |           |             |          |      |       |

### Description

This field displays the description of the input as previously programmed on the `Inputs` screen. see “`Inputs Description`,” p.20.

Record programmed parameters on the “`Input Activity Tests Worksheet`” Appendix B, p.51.

### Inact Time

This parameter allows for programming of how long the *ProTekTor+* will wait without seeing input activity before attempting to force the input *active*. The maximum inactivity duration may be specified in any one of the units specified in the table at right. The duration may be one to 9999 units or a maximum of 70 weeks, whichever is smaller. Entering zeros, “N”, “NONE”, or a space bar, sets this field to NONE. Note that if no telephone number or relay output number is programmed in the `Force Activity` field, the *ProTekTor+* will alarm once this time has elapsed with no activity.

*Time Specifications Table*

| Units               | Symbol |
|---------------------|--------|
| Clock Ticks (0.01s) | t      |
| Seconds             | s      |
| Minutes             | m      |
| Hours               | h      |
| Days                | d      |
| Weeks               | w      |

See "Modem Dialing String  
Special Characters" table  
Appendix A , p.44.

### Force Activity

This parameter allows for programming of up to a 20-digit telephone number or a relay output number that the *ProTekTor+* will use to activate the input for test purposes. For paging systems, this number could be a tone-only pager number. Any valid special character, as specified by the table in Appendix A, may be used. To delete the contents of the field enter a space. To specify a relay being used enter Rx where x is the relay number.

Behavior as a result of programmed relay type:

**Normal:** the relay will be activated for the entire Wait Time period specified in the Wait Time field. If the Wait Time is set to "none" or "0" the relay will not be actuated.

**Momentary:** the relay will be actuated for the "ON" time designated in the Time field of the relevant relay configuration entry in the Relays screen. The Input Activity wait time must still be set to a nonzero value.

**Latching:** the relay will latch until released by the Release relay command. Care must be taken that the equipment being forced active can tolerate a 100% duty cycle. The Input Activity Tests wait time must still be set to a nonzero value.

### Wait Time

This parameter allows for programming of the additional time the *ProTekTor+* will wait for activity after dialing out the specified telephone number or activating the relay output. The maximum wait time duration may be specified in any one of the units specified in the table (previous page). The wait time may be one to 9999 units or a maximum of 70 weeks, whichever is smaller. If activity has not been sensed within this time period then an alarm condition is recorded. This value should exceed all system delays expected from the time of the call to the time at which the input is forced *active*. If a zero is entered in this field, no dial out is attempted nor is any relay output activated, but the alarm immediately appears on expiration of the *Inact Time*.

### Maxact Time

This parameter allows for programming of the maximum amount of time that the input must be continuously *active* before the *ProTekTor+* alarms. The maxact time may be one to 9999 units or a maximum of 70 weeks, whichever is smaller. Entering a zero will disable the stuck active test .

### Alarm Type

This parameter allows for programming of the alarm type. Failure of either the no activity test or the stuck active test generates an alarm (types descriptions are seen on p. 21-22). Note that *QUAL* should be used if only a relay output is desired on a failure test.

See "Alarm Type" descriptions,  
p.21-22.

### Enab

This parameter allows for programming of the input as enabled "Y" or disabled "N." This serves the same function as the *Enab* field in the Inputs screens.

### Relay

This parameter allows for programming of any relay output numbers that this input test will control in its active state. Up to four relay or relay-driver outputs can be entered and delimited by a space, comma, period, or slash.

One or more modifications to this screen are logged once as:

"Site Configuration modified by "LOG IN NAME" ."

**Programming Complete!**

# 4

## Operation

This chapter concentrates on the portion of the user interface routinely used for site interrogation and control.

### Routine control of the *ProTekTor+*

Once the *ProTekTor+* has been configured (all 9 items accessible from the *Site Configuration* screen) the user will only rarely need to use these configuration screens. Most often the user will use the *Global Status* and *Commands* screens for routine interaction with the *ProTekTor+*. When the user is responding to an alert generated by the monitor as the result of site conditions, the *ProTekTor+* will immediately the *Global Status* screen so that the situation may be observed and acknowledged if desired. Should some additional action be required of the user, such as disabling an input or commanding a relay, the user may press <escape> to return to the *Main Menu*. The user may then move on to the most appropriate screen for further action. The *Commands* screen is accessible from the *Main Menu* and its use will be described in the following sections preceded by the login description..

## Password screen

This screen is automatically displayed upon successful connection and entry of several carriage returns. Enter your unique four- to eight-character alphanumeric password as programmed during the commissioning of the monitor. If the incorrect password is entered, "WRONG" will be displayed. After three unsuccessful attempts by modem, the *ProTekTor+* will disconnect. Prior to system initialization, the *ProTekTor+* accepts the default technician password 1111.

```
YOUR PASSWORD PLEASE:
```

## Main Menu

The Main Menu is displayed under normal conditions after password entry is complete. This screen is used to access all other screens by entering the desired screen number followed by <return>. To terminate the connection, enter TC.

```
Site Name: ProTekTor+  
Site ID: 1234
```

```
Time: 17:38:39  
Date: 04/26/00
```

```
ProTekTor+ v1.3  
Main Menu
```

```
1 Site Configuration  
2 Commands  
3 User Passwords  
4 History  
5 Global Status  
TC Terminate call
```

```
Enter desired screen number or Z to repaint
```

## Site Configuration

The Site Configuration screen is where most of the *ProTekTor+* personality is set. Use of the Site Configuration menu is described more completely in the previous chapter.

Site Name: ProTekTor+  
Site ID: 1234

Time: 17:38:39  
Date: 04/26/00

### Site Configuration

- 1 .Site Information
- 2 .System Parameters
- 3 .User Passwords
- 4 .Input-Alert Schedule List
- 5 .Alert Call Parameters
- 6 .Status Call Parameters
- 7 .Inputs
- 8 .Relays
- 9 .Input Activity Tests

ESCAPE key = previous, Z = repaint

## Commands

The `Commands` menu gives the user commands required for interactive control of the *ProTekTor+*. Commands fall generally into one of two categories, namely, real-time control of some aspect of the *ProTekTor+*, and configuration control or maintenance. Execution of these commands is logged in the `History`. A screen simulation and parameter descriptions follow.

```
Site Name: ProTekTor+                               Time: 17:38:39
Site ID: 1234                                       Date: 04/26/00

                                Commands

1      .Acknowledge alert
2      .Pass through
3      .Delay modem auto-answer for 3 minutes
4      .Write memory
5      .Reset
6      .Force relay on
7      .Force relay off
8      .Release relay
9      .Strobe relay
10     .Clear configuration
11     .Boot monitor
12     .Change idle time out for this session
13     .Calibrate analog inputs

ESCAPE key = previous, Z = repaint
```

### 1. Acknowledge alert

This command allows the user to acknowledge and terminate any alert call sequence in process. Entering `1 <return>` will take the full access user (technician) to the `Global Status` screen, on which the user will enter “A” `<return>` to acknowledge the alerts. After acknowledgment, all alert calls will stop, but the alarm state will remain in effect until the event that triggered the alarm is rectified.

### 2. Pass through

This command allows the user to access the serial port remotely. Giving this command while connected by modem will pass all subsequent traffic to the DE-9 serial port. This command is not available when connected to the *ProTekTor+* via the local serial port.

All serial port commands start with a tilde character at the beginning of a line, as in the Unix “tip” utility. The following commands are presently available:

~ ~            Send a tilde out the front panel

~            .Disconnect

### 3. Delay modem auto-answer for 3 minutes

This command allows the user to program the *ProTekTor+* to ignore any inbound ring so as to allow another modem sharing the line to answer. This allows a user to log onto the *ProTekTor+* by modem, inhibit the *ProTekTor+* Telco auto-answer, quickly disconnect, and connect to a secondary device on the same POTS line. This does not inhibit outbound alert calls occurring during the three-minute period. Auto-answer will automatically be restored after three minutes. Any secondary device on the POTS line must be set to answer upon receipt of more than one ring. For example, since the *ProTekTor+* will generally answer on the first or second ring (depending upon alert call state) a secondary device would be set to answer after three or more rings. The *ProTekTor+* modem and any other modem on the line will negotiate outbound calls via their respective CD (carrier detect) functionality. This action is not logged in the History.

### 4. Write Memory

This command writes the current configuration to the flash memory. It will be logged in the History as "Configuration written to memory by "LOG IN NAME"."

### 5. Reset

This command orders a soft reset that is equivalent to a power cycle of the *ProTekTor+* and may be used if power glitches or other transients are believed to be causing some anomalous operation. The reset is logged in the History as "POWER ON".

### 6. Force relay on

This command removes the relay from any programmed autonomous operation and sets the relay *on* until it is manually released. A *Force relay off* command will toggle the relay state but does not return the relay to system control. This command is logged in the History as "Rx (RELAY DESCRIPTION) Forced On by "LOG ON NAME"."

### 7. Force relay off

This command removes the relay from any programmed autonomous operation and sets the relay *off* until it is manually released. A *Force relay on* command will toggle the relay state but does not return the relay to system control. This command is logged in the History as "Rx (RELAY DESCRIPTION) Forced Off by "LOG ON NAME"."

### 8. Release relay

This command returns the relay to any autonomous system control as programmed by the user on the *Relays* screen. This command is logged in the History as "Rx (RELAY DESCRIPTION) Released by "LOG ON NAME"."

See "Relays" screen, p.23.

### 9. Strobe relay

This command will manually strobe the relay for a short duration as programmed by the user on the *Relays* screen. A forced relay will ignore a strobe relay command. A relay already being controlled autonomously will also ignore the strobe command. This command is logged in the History as "Rx (RELAY DESCRIPTION) Strobed by "LOG ON NAME"."

See "Relays" screen, p.23.

#### 10. Clear configuration

This command deletes all user programming and returns the operating system to the default configuration. It does not clear the History and this action is not logged in the History. The user will receive the prompt “All configuration data will be cleared! Continue? (y/n).” Enter “y” to clear the programming.

#### 11. Boot monitor

The command places the monitor in debug mode for flash upgrade. This action is not logged in the History.

While rarely needed, this command allows the user to access the boot> prompt for download or reset. After entering the Boot monitor command the “boot>” prompt appears. Follow this prompt by entering <return> and the commands menu appears (as seen below). Choose the desired command followed by <return>. Refer to Appendix A, p.45 for the complete flash modem upgrade procedure.

See “Flash Modem Upgrade Procedure” Appendix A. p.45.

```
PageTek boot monitor $Revision: 1.7 $  
  
Commands:  
  
d   Start xmodem download of new flash image  
r   Reset  
c   Run main program without checking sum (dangerous)
```

#### 12. Change idle time out for this session

This command allows for an extension of the time for which a connection may remain idle without being disconnected by the *ProTekTor+*. This action is not logged in the History.

#### 13. Calibrate analog inputs

This command sets the zero point of any input configured as an analog type. Ensure that no voltages are applied to the inputs when this command is given. This action is not logged in the History.

## Global Status screen

The Global status screen is a read-only screen indicating the real-time state of all inputs and relays. The status of any alert call, relay, and/or input is displayed. This screen is automatically displayed upon log-in and log-out if there are any alert calls in progress. Otherwise, this screen is accessed via the Main Menu. Due to the high information density a screen refresh cycle takes more than one second and the active times may therefore seem to jump by two seconds. A screen simulation and field descriptions follow.

|                               |                   |                |                    |                            |              |          |              |                  |
|-------------------------------|-------------------|----------------|--------------------|----------------------------|--------------|----------|--------------|------------------|
| Site Name: ProTekTor+         |                   | Time: 17:38:39 |                    |                            |              |          |              |                  |
| Site ID: 1234                 |                   | Date: 04/26/00 |                    |                            |              |          |              |                  |
| Global Status                 |                   |                |                    |                            |              |          |              |                  |
| Alert Calls: none in progress |                   |                |                    |                            |              |          |              |                  |
| #                             | Relay             | State          | Controlling Inputs | Controlling Activity Tests |              |          |              |                  |
| 1.                            | Relay 1           | LATCHED ON     | 1,5                | 1                          |              |          |              |                  |
| 2.                            | Relay 2           | ON             | 2                  | 1                          |              |          |              |                  |
| 3.                            | Relay 3           | OFF            | 3                  | 1                          |              |          |              |                  |
| 4.                            | Relay 4           | OFF            | 4                  | 1                          |              |          |              |                  |
| #                             | Input Description | State          | Level              | Qlf By                     | Alert Active | Activity | Active Today | Active Yesterday |
| 1.                            |                   | DISABLED       | OPEN               | 0                          | N            | OK       | 00:00:00     | 00:00:00         |
| 2                             |                   | .DISABLED      | OPEN               | 0                          | N            | OK       | 00:00:00     | 00:00:00         |
| 3                             |                   | .DISABLED      | OPEN               | 0                          | N            | OK       | 00:00:00     | 00:00:00         |
| 4                             |                   | .DISABLED      | OPEN               | 0                          | N            | OK       | 00:00:00     | 00:00:00         |
| 5                             |                   | .DISABLED      | +00.3V             | 0                          | N            | OK       | 00:00:00     | 00:00:00         |
| 6                             |                   | .DISABLED      | +0.03V             | 0                          | N            | OK       | 00:00:00     | 00:00:00         |
| 7                             |                   | .DISABLED      | -00.3V             | 0                          | N            | OK       | 00:00:00     | 00:00:00         |
| 8                             |                   | .DISABLED      | -0.03V             | 0                          | N            | OK       | 00:00:00     | 00:00:00         |

### Alert Calls

This field displays messages according to the system status. If there are no alert calls in progress the *ProTekTor+* will display: "none in progress." If the alert call sequence is disabled, the system displays "DISABLED." If the alert call sequence is active, the system displays: "in progress."

### Relay

This field indicates the description that has been programmed by a full access user (technician) on the Relays screen. This description will be used by the alert messages and by the History logging.

### State

This field indicates the state of the relay. State descriptions are as follows:

|           |   |
|-----------|---|
| ON        | The relay has been activated by the system as previously programmed by the user. Generally this means that a controlling input has gone active. |
| OFF       | The relay is not activated and is awaiting command.   |
| FORCED ON | The relay has been Forced On by the user and is no longer available to any previously programmed system control.                                |

**FORCED OFF** The relay has been Forced Off by the user and is not available to any previously programmed system control.

**LATCHED ON** The relay, which has been configured by the user as a latching type, has been activated by the system and will remain Latched On until released by the Release relay command.

#### Controlling Inputs

See pp. 20-22.

This field indicates the inputs that will actuate this relay when in the active state. Inputs are programmed via the `Site Configuration` screen.

#### Controlling Activity Tests

See "Inputs" screen, p.20.

This field indicates the activity test that have been programmed to attempt to force activity using this relay. As an example, if the *ProTekTro+* is monitoring the activity of a transmitter key line on `Input 3` and observes an abnormal period of inactivity, the activity test could actuate a relay interfaced to the key line in an attempt to force activity. In this case, the "controlling activity test" would be that particular activity test programmed to monitor `Input 3` (programmed on the `Input Activity Test` screen). The relay to be actuated would be programmed in the `Relay` field of the `Input 3` activity test programming.

The bottom half of the `Global Status` screen displays information pertaining to the eight inputs. An input is considered "disabled" under either of two circumstances. First, an input is considered disabled if the input is not enabled via the `Inputs` screen. Second, an input is considered disabled if the input's qualifier is not in the *active* state.

#### Input Description

This field indicates the input description as entered in the `Inputs` screen accessed by a full access user. A description of up to 16 alphanumeric characters may be entered there and will identify the input in any alert or status messages.

#### State

This field indicates the current state of each installed input. State descriptions are as follows:

**NORMAL** The input is within accepted limits as programmed by the user.

**ACTIVE** The input is enabled, and has been outside the user programmed limits for a period exceeding that specified in the `Time Delay` field. Since an *active* status indication is used only by an input programmed as a `Qualifier`, this means that the triggering event was not logged in the `History` and no front panel Alarm LED will be illuminated.

**MINOR** The input is outside of the user programmed limits and is presently in a minor alarm state, meaning that an alert call sequence has not and will not be sent, but the event has been logged in the `History` file. The Alarm LED will be illuminated.

|          |   |
|----------|---|
| MAJOR    | The input is presently outside the allowable limits programmed by the user. An alert call will result from an input being in a MAJOR state, though the alert call sequence need not be currently active. The Alarm LED will be illuminated.   |
| DELAY    | The input is not disabled, and has been in the active level for a time period less than that input's specified Time Delay. The Alarm LED will be illuminated only after the delay period has expired.   |
| DISABLED | The input has not been enabled by the user. Even though a disabled input will not initiate alert call sequences or relay reaction, any voltage or state measured by this input will still be displayed on the Global Status screen. An input disabled after an alert call has been initiated will clear the alarm state and extinguish the Alarm LED, but will not cancel the alert call sequence that may still be active. |

#### Level

This field indicates the current Level of the input as OPEN or CLOSED for inputs configured as digital. A numeric value will be indicated for any input configured as an analog input. This reading is not affected by whether or not the input is disabled, nor by the time delay setting.

#### Qlfd By

This field indicates the number of the input (0 - 8) by which the current input is qualified (the number of the input that must be active before this one can be). Note that a zero indicates no qualification.

#### Alert Active

This field indicates whether the input has an alert in progress where "Y" indicates an alert is in progress and has not yet been acknowledged and "N" indicates no alert is in progress. If there are no alerts in progress the command options displayed are: "ESCAPE key = previous, Z = repaint." However, if there is at least one alert in progress the command options displayed are: "ESCAPE key = previous, Z = repaint, A = acknowledge alerts in progress." If the later is the case, acknowledge the alerts by the command A <return>. The Alarm LED will generally be illuminated, unless the input has been disabled after the alarm occurred.

#### Activity

This field will indicate whether there is an alarm due to an activity test associated with this input. The Alarm LED will be illuminated if there is an activity alarm in effect. Those activity tests that are programmed to attempt to force activity by dialing a phone number or actuating a relay, will not generate an alarm until that attempt has failed.

#### Active Today

This field indicates in 24-hour format the total time that the input has been active since the most recent midnight.

#### Active Yesterday

This field indicates in 24-hour format the total time that the input was active in the 24-hour period preceding the most recent midnight.



# Appendix

# A

## Configuration Plugs Description

| Supported Configuration Plug                     | Measured Volage Range   | Units  |
|--|---|--|
| Closure<br>(sometimes erroneously calld digital) | <i>Active</i> if external contact closes and pulls internal 5 VDC pull up to ground | Indicated in logic levels of HIGH (H) or LOW (L) |
| 5  | -2.5 VDC to 5.00 VDC<br>(Analog )   | (V) Volts  |
| 50   | -25.0 VDC to 50.00 VDC<br>(Analog )   | (V) Volts  |
| -5   | -5.00V DC to +2.5 VDC<br>(Analog )  | (V) Volts  |
| -50  | -50.00 VDC to +25 VDC<br>(Analog )  | (V) Volts  |
| Telewave   | Supports the Telewave<br>PM-2A RF sensors   | (W ) Watts                                       |

## Voltage to Wattage Conversion Tables

### Uniform Voltage Scale

|                |     |    |     |    |     |     |     |     |     |     |     |     |     |     |     |     |     |
|----------------|-----|----|-----|----|-----|-----|-----|-----|-----|-----|-----|-----|-----|-----|-----|-----|-----|
| <b>Voltage</b> | 0.5 | 1  | 1.5 | 2  | 2.5 | 3   | 3.5 | 4   | 4.5 | 5   | 5.5 | 6   | 6.5 | 7   | 7.5 | 8   | 8.4 |
| <b>Wattage</b> | 7   | 22 | 50  | 77 | 116 | 159 | 208 | 267 | 322 | 400 | 476 | 553 | 643 | 738 | 823 | 921 | 999 |

### Uniform Wattage Scale

|                |      |     |      |      |      |      |      |      |      |      |      |      |
|----------------|------|-----|------|------|------|------|------|------|------|------|------|------|
| <b>Voltage</b> | 0.6  | 1.1 | 1.5  | 1.7  | 2.3  | 2.66 | 2.9  | 3.2  | 3.44 | 3.92 | 4.3  | 4.75 |
| <b>Wattage</b> | 10   | 25  | 50   | 75   | 100  | 125  | 150  | 175  | 200  | 250  | 300  | 350  |
| <b>Voltage</b> | 4.75 | 5   | 5.44 | 5.75 | 6.09 | 6.67 | 6.83 | 6.93 | 7.26 | 7.5  | 8.01 | 8.4  |
| <b>Wattage</b> | 350  | 400 | 450  | 500  | 550  | 600  | 650  | 700  | 750  | 800  | 900  | 999  |

## Voltage - Temperature Table

|                |      |      |      |      |      |      |      |      |      |      |      |      |     |     |
|----------------|------|------|------|------|------|------|------|------|------|------|------|------|-----|-----|
| <b>Voltage</b> | 0.20 | 0.30 | 0.40 | 0.50 | 0.55 | 0.60 | 0.65 | 0.70 | 0.75 | 0.80 | 0.85 | 0.90 | 1.0 | 1.1 |
| <b>°C</b>      | <=1  | <=1  | 1-14 | -3   | 2    | 7    | 12   | 17   | 21   | 27   | -    | 37   | 47  | 57  |

# Board Layout

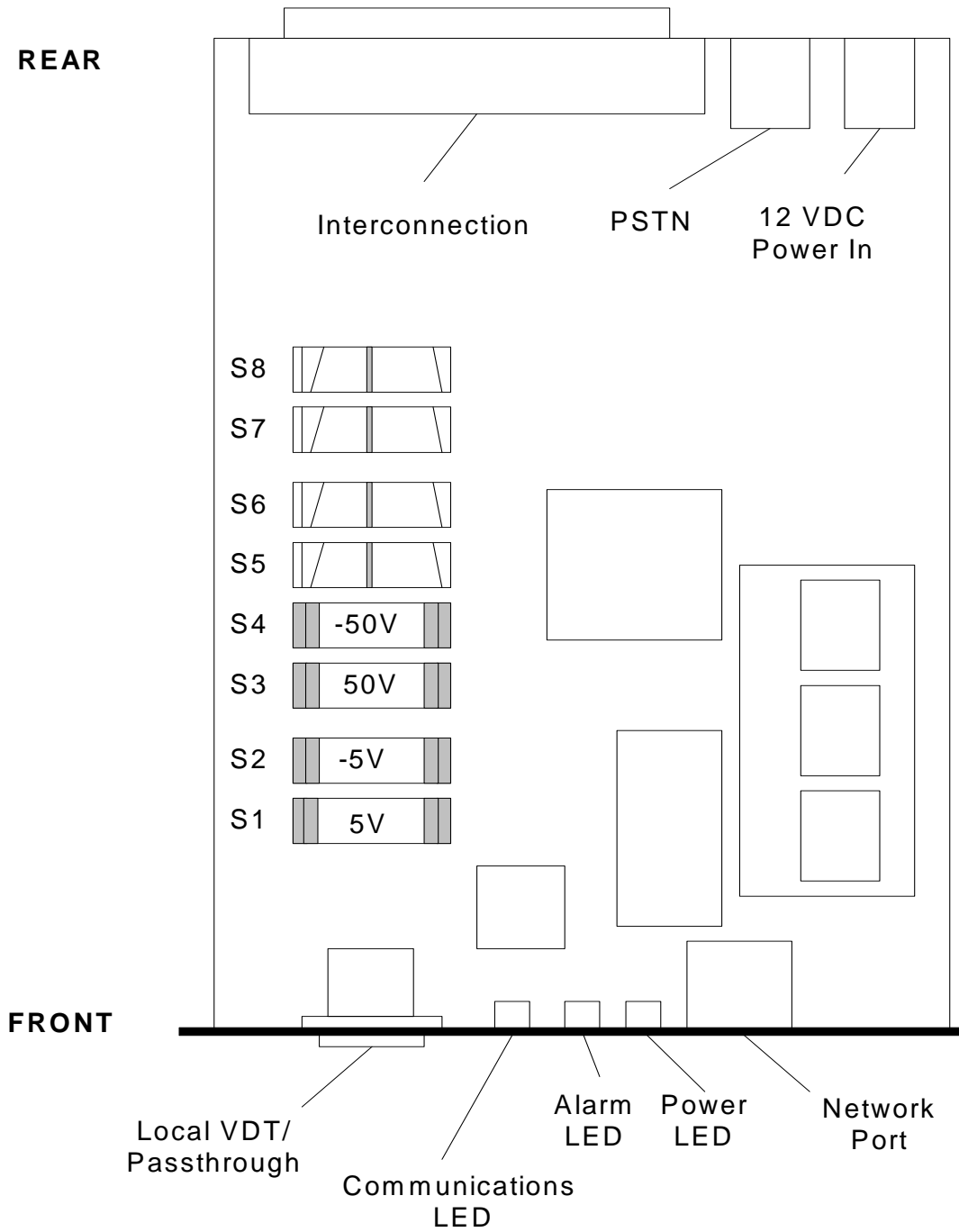

# Front and Rear Panel Layouts

*ProTekTor+* Front Panel

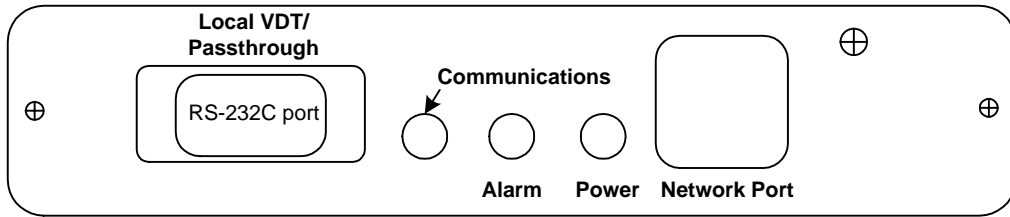

*ProTekTor+* Rear Panel

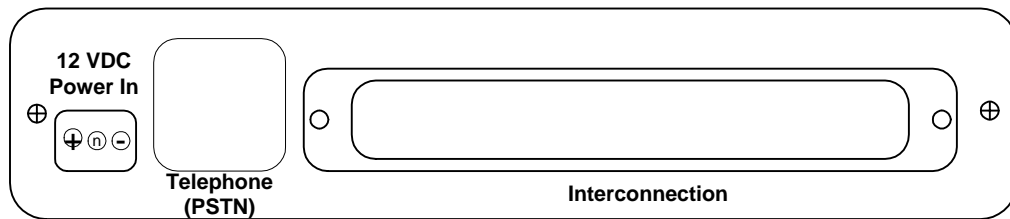

## Interface Connector Function by Pin-out

| RJ-21<br>PIN | Color Code      | ProTekTor+         | Notes                              |
|--------------|-----------------|--------------------|------------------------------------|
| 01           | Blue/White      | Input 1 High       |                                    |
| 02           | Orange/White    | Input 2 High       |                                    |
| 03           | Green/White     | Input 3 High       |                                    |
| 04           | Brown/White     | Input 4 High       |                                    |
| 05           | Gray/White      | Input 5 High       |                                    |
| 06           | Blue/Red        | Input 6 High       |                                    |
| 07           | Orange/Red      | Input 7 High       |                                    |
| 08           | Green/Red       | Input 8 High       |                                    |
| 09           | Brown/Red       | Relay 1A NO        | -                                  |
| 10           | Gray/Red        | Relay 1A NC        |                                    |
| 11           | Blue/Black      | Relay 2A NO        | Since both poles of relays 1 and 2 |
| 12           | Orange/Black    | Relay 2A NC        | are available, these relays may be |
| 13           | Green/Black     | Relay 1B NO        | used for switching balanced        |
| 14           | Brown/Black     | Relay 1B NC        | circuits, if required.             |
| 15           | Gray/Black      | Relay 2B NO        |                                    |
| 16           | Blue/Yellow     | Relay 2B NC        | -                                  |
| 17           | Orange, /Yellow | Relay 3A NO        |                                    |
| 18           | Green/Yellow    | Relay 3B NC        |                                    |
| 19           | Brown/Yellow    | Relay 4A NO        |                                    |
| 20           | Gray/Yellow     | Relay 4B NC        |                                    |
| 21           | Blue/Purple     | Relay Driver 1     |                                    |
| 22           | Orange/Purple   | Relay Driver 3     |                                    |
| 23           | Green/Purple    | Relay Driver 5     |                                    |
| 24           | Brown/Purple    | 5VDC Return        |                                    |
| 25           | Gray/Purple     | 12VDC Return       |                                    |
| 26           | White/Blue      | Input 1 Low        |                                    |
| 27           | White/Orange    | Input 2 Low        |                                    |
| 28           | White/Green     | Input 3 Low        |                                    |
| 29           | White/Brown     | Input 4 Low        |                                    |
| 30           | White/Gray      | Input 5 Low        |                                    |
| 31           | Red/Blue        | Input 6 Low        |                                    |
| 32           | Red/Orange      | Input 7 Low        |                                    |
| 33           | Red/Green       | Input 8 Low        |                                    |
| 34           | Red/Brown       | Relay 1A NO Return |                                    |
| 35           | Red/Gray        | Relay 1A NC Return |                                    |
| 36           | Black/Blue      | Relay 2A NO Return |                                    |
| 37           | Black/Orange    | Relay 2A NC Return |                                    |
| 38           | Black/Green     | Relay 1B NO Return |                                    |
| 39           | Black/Brown     | Relay 1B NC Return |                                    |
| 40           | Black/Gray      | Relay 2B NO Return |                                    |
| 41           | Yellow/Blue     | Relay 2B NC Return |                                    |
| 42           | Yellow/Orange   | Relay 3A NO Return |                                    |
| 43           | Yellow/Green    | Relay 3B NC Return |                                    |
| 44           | Yellow/Brown    | Relay 4A NO Return |                                    |
| 45           | Yellow/Gray     | Relay 4B NC Return |                                    |
| 46           | Purple/Blue     | Relay Driver 2     |                                    |
| 47           | Purple/Orange   | Relay Driver 4     |                                    |
| 48           | Purple/Green    | Relay Driver 6     |                                    |
| 49           | Purple/Brown    | 5VDC               | JU7 must be installed              |
| 50           | Purple/Gray     | 12VDC              | 12VDC                              |



## History Log Descriptions

| Log Entry  | Event  |
|--|--|
| <b>Commands</b>  |  |
| Configuration written to memory by "user name"                                   | Configuration written to flash memory by Write Memory command.                               |
| Configuration cleared by "user name"   | Configuration cleared by Clear Configuration command.  |
| Power-on   | System reset by Reset command or in result of power glitches.                                |
| Rx (RELAY DESCRIPTION) Forced On by "user name"                                  | Relay forced on by Force relay on command.   |
| Rx (RELAY DESCRIPTION) Forced Off by "user name"                                 | Relay forced off by Force relay off command.   |
| Rx (RELAY DESCRIPTION) Released by "user name"                                   | Relay released by Release relay command.   |
| Rx (RELAY DESCRIPTION) Strobed by "user name"                                    | Relay strobed by Strobe relay command.   |
| <b>Terminal</b>  |  |
| User "operator name/number" logged in  | Successful password entry for user login at local/remote terminal.                           |
| Invalid terminal password "password" entered                                     | Invalid password entry for user login at local/remote terminal.                              |
| User "user name" logged out  | User logout or idle timeout at local/remote terminal.  |
| Alerts acknowledged by "user name"   | Alert calls acknowledged by a terminal user via the Global Status.                           |
| Status call parameters modified by "user name"                                   | Status calls modified by a terminal user via the Global Status.                              |
| Alert call parameters modified by "user name"                                    | Alert calls modified by a terminal user via the Global Status.                               |
| Idle time out on modem<br>Idle time out on local port                            | Idle timeout limit exceeded at login prompt or while logged in.                              |
| Modem carrier lost   | Modem carrier lost while user is logged in via modem.  |
| Config written to memory by "operator name/number"                               | Configuration written to flash memory by Write Memory command or at logout.                  |
| Alarm: # (input name) OPEN<br>Return to normal: # (input name) CLOSED            | Alarm enabled from local/remote terminal user.   |
| Debug mode entered by "user name"  | Successful debug password entered for debug mode. (initiated by PageTek only).               |
| Return to normal: X (input name) OPEN<br>Return to normal: X (input name) CLOSED | Auxiliary input (MAJ, MIN, or RTN) went from ALARM state to NORMAL state at specified level. |

## History Log Descriptions cont.

| <b>Modem Calls</b>   |  |
|--|--|
| Calling number X   | Alert/Status call attempted to a targeted number by GateKeeper.                              |
| Calling #X: Modem result - "CONNECT 14400" (15)<br>Calling #X: TAP result - "message: ACK"<br>Calling #X: TAP failure - "didn't get 'ID #'"<br>Answering call: Modem result - "CONNECT 9600" (12)" | Modem result code returned by modem for all modem calls initiated or answered by GateKeeper. |
| <b>Site Configuration</b>  |  |
| User #X added by "user name"   | Terminal user added by a terminal user.  |
| User #X deleted by "user name"   | Terminal user deleted by a terminal user.  |
| User #X modified by "user name"  | Terminal user modified by a terminal user.   |
| Alert call parameters modified by "user name"  | Alert call parameters modified by a terminal user.   |
| Alert calls disabled by "user name"  | Alert call parameters disabled by a terminal user.   |
| Alert calls enabled by "user name"   | Alert call parameters enabled by a terminal user.  |
| Site configuration modified by "user name"   | Configuration cleared by a terminal user.  |
| Site configuration modified by "user name"   | Site configuration modified by a terminal user.  |
| <b>Inputs</b>  |  |
| Alarm X (input name) OPEN<br>Alarm X (input name) CLOSED   | Auxiliary input (MAJ, MIN, or RIN) went into ALARM state at specified level.                 |
| Return to normal: X (input name) OPEN<br>Return to normal: X (input name) CLOSED   | Auxiliary input (MAJ, MIN, or RIN) went from ALARM state to NORMAL state at specified level. |
| <b>Miscellaneous</b>   |  |
| Power-on   | Power cycled and system reset by a terminal user.  |
| Unknown event  | Unknown event occurred.  |

## Modem Dialing String Special Characters

| Character | Meaning                              | Use  |
|-----------|--------------------------------------|--|
| *         | The 'star' digit (tone dialing only) | Specified by system being called.  |
| #         | The 'gate' digit (tone dialing only) | Specified by system being called.  |
| a-d       | DTMF digits a,b,c,d                  | Specified by system being called.  |
| p         | Select pulse dialing                 | The modem will pulse dial the numbers that follow the "p" until a "t" is encountered then the modem reverts to tone dialing.                 |
| t         | Select tone dialing                  | The modem will tone dial the numbers that follow the "t" until a "p" is encountered, then the modem reverts to pulse dialing.                |
| !         | Flash                                | The modem will go on-hook for a time defined by the value of S29.  |
| w         | Wait for dial tone                   | The modem will wait for a dial tone then dial the digits following "w".  |
| @         | Wait for silence                     | The modem will wait for at least 5 seconds of silence in the call progress frequency band then continue with the next dial string parameter. |
| &         | Wait for credit card dialing tone    | The modem will wait for a specified time then continue with the dialing string.  |
| ,         | Dial pulse                           | The modem will pause for a specified time then dial the digits following ",".  |
| ^         | Toggles calling tone                 | Identifies the calling tone as enabled or disabled.  |
| ()        | None                                 | Ignored character used to format dialing.  |
| -         | None                                 | Ignored character used to format dialing.  |
| <space>   | None                                 | Ignored character used to format dialing.  |
| >         | Generate grounding pulse             | The modem will generate a grounding pulse on the EARTH relay output.   |

# ProTekTor+ Flash Upgrade Procedure

## Obtain Flash Upgrade

Flash upgrades are available on our Web site, via email, floppy disc, or on CD. Place the flash image in a location from where it can be easily downloaded via any terminal emulation application supporting X-Modem.

## Access the boot monitor locally or via modem

**From the local terminal only:** Login with a full access password and go to **Commands** from the **Main Menu**; choose **Reset** (item 5) followed by entering <return>.

**Via modem** (or local terminal): Login with a full access password and go to **Commands** from the **Main Menu**; choose **Boot monitor** (item 11) followed by entering <return>.

In either case, the prompt “Press ESC within 10 seconds to enter boot monitor” appears. Enter <escape> and at the boot prompt enter <return>. The following display will appear:

```
PageTek boot monitor $Revision: 1.7 $

Commands:
d   Start xmodem download of new flash image
r   Reset
C   Run main program without checking sum (dangerous)

boot>_
```

## Start the download

(Proceed quickly, event will be timed out and returned to boot> after 30sec.)

- 1 .Enter **d** <return> to start download of new flash image. The terminal will prompt: “Downloading...Start sending new image now”.
- 2 .Select appropriate **Folder, Filename, and Protocol** (Xmodem or Xmodem 1K protocol) and hit **Send**.

Upon a successful download the local terminal displays “Succeeded, resetting.” In this event, enter <escape> within 10 seconds and initiate startup procedures as normal. If the download was not successful one of two things will happen: a failure message is printed and a new boot> prompt is issued or the local monitor displays “Failed: You cancelled. Try again.” In either case enter another d command and try the download again.

## Possible problems and required action

| <b>Problem</b>                         | <b>Action</b>  |
|--|--|
| Accidentally entering the boot monitor | Enter “r” to reset the processor                                   |
| Download fails, no messages            | Try Ctrl-X several times to stop the failed download, then restart |
| Bad line or defective flash file       | Correct problem and restart download                               |

# Alert Call Message Structure

## Messages sent to alphanumeric pager via SNPP:

```
IP 1234: Test site
Input: 01/01/00 22:16:50
Input 1 Unacked: 1
Current: 1 09/12 01:57 PM EDT
IP STATUS 1234: Test site
Current: 1 09/12 12:40 PM EDT
```

## Messages sent to alphanumeric pager via TAPP:

(message may format differently on different pagers)

```
Alert call:
1234: ProTekTor+ Demo
Input: 04/27/00 10:18:53 Input 2 Label
Unacked: 1,2 Current: 1,2
Status call:
STATUS 1234: ProTekTor+ Demo
Unacked: 1,2 Current: 1,2
Input (Input 2 Label, etc) and site labels (ProTekTor+IP, etc) are variable length
fields and may contain 0 to 16 characters.
```

## Messages sent to modem or TCP/IP port:

```
Alert call - Site 2222: ProTekTor+IP
Alert sent: 10/01/00 16:34:25
Latest input alarm: 10/01/00 16:30:03 AC Power Failure
Present and recent alarms:
AC Power Failure: OPEN UNACKED CURRENT
```

## Messages sent to a numeric pager by *ProTekTor+*

It is possible to send an alarm to a numeric pager. To do so, select type as MODEM, enter the pager number in the Modem number field, followed by a delay character (commas or @) followed by the Site ID number. Some systems may also require an additional entry to navigate the front end of a voice mail box system. The following string is known to work on such a system:

```
1888555555@1@1234
```

In the example above, the pager number 1-888-555-5555 is dialed, the *ProTekTor+* waits for five seconds of quiet, sends a 1 to specify a numeric page, waits for a further five seconds of silence, and then sends the Site ID of 1234. In the example above, commas could be used instead of the @ to send the message after a fixed wait period. Some degree of experimentation may be required to confirm the best values. It may be helpful to monitor the interaction of the terminal and the *ProTekTor+* during the initial set up.

The pager will receive the Site ID (ex: 1234). The user may wish to prefix the Site ID with 911 to indicate a greater sense of urgency. Some systems may allow the message urgency to be set in the dial string. Refer to your carrier for further details.

# Appendix

# B

## System Configuration Worksheets

### Site Information Worksheet

**Site Id:**\_\_\_\_\_ (4 digit number)

**Site Name:**\_\_\_\_\_ (16 character  
alphanumeric string)

**Date:** UCT used (Y/N)

**Time:** UCT used (Y/N)

### System Parameters Worksheet

Detailed TAPP log messages enabled: (Y/N)\_\_\_\_

Alert Calls Enabled: (Y/N)\_\_\_\_

## User Passwords Worksheet

| ACCESS RIGHTS                                   | NAME<br>(20 characters) | PASSWORD<br>(4-8 characters) |
|---|-------------------------|------------------------------|
| <b>OBSERVER (READ-ONLY)</b><br>(limited access) |                         |                              |
| 1   |                         |                              |
| 2   |                         |                              |
| 3   |                         |                              |
| 4   |                         |                              |
| 5   |                         |                              |
| 6   |                         |                              |
| <b>TECHNICIAN (READ/WRITE)</b><br>(full access) |                         |                              |
| 1   |                         |                              |
| 2   |                         |                              |
| 3   |                         |                              |
| 4   |                         |                              |
| 5   |                         |                              |
| 6   |                         |                              |

### Input-Alert Schedule List Worksheet

| SCH | START TIME<br>(HH:MM:SS) | END TIME<br>(HH:MM:SS) | DAYS<br>(MTWUFSU) |
|-----|--------------------------|------------------------|-------------------|
| 1   |                          |                        |                   |
| 2   |                          |                        |                   |
| 3   |                          |                        |                   |
| 4   |                          |                        |                   |
| 5   |                          |                        |                   |

### Alert Call Parameters Worksheet

| # | TYPE<br>(Modem/Pager) | SCHEDULE QUAL<br>(1-5) | MODEM NUMBER<br>(40 characters) | PAGER NUMBER<br>(16 characters) |
|---|-----------------------|------------------------|---------------------------------|---------------------------------|
| 1 |                       |                        |                                 |                                 |
| 2 |                       |                        |                                 |                                 |
| 3 |                       |                        |                                 |                                 |
| 4 |                       |                        |                                 |                                 |
| 5 |                       |                        |                                 |                                 |
| 6 |                       |                        |                                 |                                 |
| 7 |                       |                        |                                 |                                 |
| 8 |                       |                        |                                 |                                 |

Call Sequence: \_\_\_\_\_ (1-8)

Attempts per Number: \_\_\_\_\_ (1-225 min.)

Interval Between Calls: \_\_\_\_\_ (1-225 min.)

Sequence Repetitions: \_\_\_\_\_ (1-225 min.)

## Status Call Parameters Worksheet

Number for Status Call: \_\_\_\_\_ (0-8)

Date/Time for next Status Call: \_\_\_\_\_ / \_\_\_\_\_ (HH:MM:SS / MM/DD/YY)

Interval Between Status Calls: \_\_\_\_\_ (1-225)

## Inputs Worksheet

| INP # | INPUT DESCRIPTION<br>(16 character) | NORMAL LEVEL<br>(open/closed or specified range) | QLFD BY<br>(1-8) | TIME DELY<br>(1-255s) | ALRM TYPE<br>(min, maj, rtn, qual) | ENB<br>(Y/N) | RELAYS<br>(any 4 of #1-8) | SCHED<br>(1-8) |
|-------|-------------------------------------|--|------------------|-----------------------|------------------------------------|--------------|---------------------------|----------------|
| 1     |                                     |  |                  |                       |                                    |              |                           |                |
| 2     |                                     |  |                  |                       |                                    |              |                           |                |
| 3     |                                     |  |                  |                       |                                    |              |                           |                |
| 4     |                                     |  |                  |                       |                                    |              |                           |                |
| 5     |                                     |  |                  |                       |                                    |              |                           |                |
| 6     |                                     |  |                  |                       |                                    |              |                           |                |
| 7     |                                     |  |                  |                       |                                    |              |                           |                |
| 8     |                                     |  |                  |                       |                                    |              |                           |                |

## Relays Worksheet

| # | DESCRIPTION<br>(20 characters) | TYPE<br>(normal, latching,<br>momentary) | TIME<br>(0-99 sec) | CONTROLLING<br>INPUTS<br>(1-8) | CONTROLLING<br>ACTIVITY TESTS<br>(1-8) |
|---|--------------------------------|--|--------------------|--------------------------------|--|
| 1 |                                |  |                    |                                |  |
| 2 |                                |  |                    |                                |  |
| 3 |                                |  |                    |                                |  |
| 4 |                                |  |                    |                                |  |

## Input Activity Tests Worksheet

| # | INACT<br>TIME<br>(1s-70<br>weeks) | FORCE<br>ACTIVITY<br>(20 digits) | WAIT<br>TIME<br>(1s-70<br>weeks) | MAXACT<br>TIME<br>(1s-70<br>weeks) | ALM<br>TYPE<br>(MIN, MAJ,<br>RTN, QUAL) | ENAB<br>(Y/N) | RELAYS<br>(1-4) |
|---|-----------------------------------|----------------------------------|----------------------------------|------------------------------------|---|---------------|-----------------|
| 1 |                                   |                                  |                                  |                                    |   |               |                 |
| 2 |                                   |                                  |                                  |                                    |   |               |                 |
| 3 |                                   |                                  |                                  |                                    |   |               |                 |
| 4 |                                   |                                  |                                  |                                    |   |               |                 |
| 5 |                                   |                                  |                                  |                                    |   |               |                 |
| 6 |                                   |                                  |                                  |                                    |   |               |                 |
| 7 |                                   |                                  |                                  |                                    |   |               |                 |
| 8 |                                   |                                  |                                  |                                    |   |               |                 |



# Appendix

# C

## Addendums

### **Contact closure only inputs**

Note that field configuration is impossible because socketed configuration plugs are not used.

### **Modemless operation**

It is possible to use the *ProTekTor+* in a Local Mode only manner. At present local alarm indication will be the Alarm LED on the *ProTekTor+* front panel or by assignment of a relay to actuate a local annunciator. The serial port may be configured to send alert and status messages. Protocol for the communications must be specified by the user so that custom code may be developed.

The *ProTekTor+* may be configured to use a static ram instead of the NVRAM/real-time clock. Such use requires that a dependable 12 VDC supply be supplied by the user. History, real-time, and date will be lost if 12 VDC input fails.

### ***ProTekTor+* Stripped Down Version--Behavior**

### **Static Ram Operation**



# Appendix

# D

## Specifications

### Mechanical

Cabinet Dimensions: 5" Wide x 1.75" High x 8" Deep

Weight: 1 lbs.

Mounting: tabletop

Operating Temperature: -30° to 60° Celsius

### Electrical

#### Interface Connectors.

50-pin RJ-21 connector for analog inputs, digital inputs, audio inputs, and relay-driver outputs

DE-9 connector for local port RS-232C communications

RJ-11 modular telephone jack

2-Pin Molex™ connector for DC Power Input

RJ-45 connector for TCP/IP or RS-485 network

#### Power:

AC Power Input: 115 VAC Wall Mount Transformer, 12 VDC output

DC Power input: 12 VDC nominal (10.5 - 18 V)

Power Consumption: 1 W maximum

Benching Marq NVRAM, 10 year lifespan

#### VDTs Supported:

ANSI / VT-100

### Interface Specifications

#### Inputs:

Each analog configured input has 2 selectable voltage ranges: 0-5, and 0-50.

Input impedance: 100K ohms

Maximum input voltage: ±50 VDC

Resolution is ± 0.4% of full scale

Accuracy for DCV

Accuracy for Watts: ±5%

Each digital configured input accepts TTL or EIA levels

Low level -12 to +0.8 VDC

High level +2.4 to +12 VDC

Undriven state is high (pulled up through an internal resistor to +12 VDC)

The input is diode protected internally against negative voltages

Active level is user programmable

### **Relay Drivers:**

*Standard ProTekTor+*

Four relay drivers designated R1-R4. Each driver is an open collector capable of sinking 100 mA @ 32 VDC maximum

*ProTekTor+ Relays Option*

Four DPDT relays designated R1-R4. Each is capable of 1 A at 120 VAC

### **RS-232C Port**

*Standard ProTekTor+*

Asynchronous Serial RS-232C interface, DCE or DTE

1 Start, 8 Data, 1 Stop Bits (No parity)

XON-XOFF Flow Control

Internal Modem Port baud rate: 14.4 KBPS V.32 bits

baud rate: 1200, 9600, 19200, 38400

### **Telco Coupler:**

Standard Loop Start Interface with Tone Signal (Meets Part 68 of FCC Requirements for Network Interface)

Ringer Equivalence Number: 0.2

### **IP Specs:**

Ethernet Version 2.0/IEEE 802.3

RJ-45 (10Base-T)

Protocols: Telnet, TFTP, UDP, TCP/IP DHCP, ARP

SNMP (server read-only)

Server flash remotely upgradable

### A-L

**100% duty cycle:** The time interval occupied by a device on intermittent duty in starting, running, stopping, and idling.

**Active State:** An input is outside the user programmed limits for a period exceeding a specified time.

**Cap code:** The ID programmed in a pager and sent by the paging system to alert the pager that the subsequent message is intended for that particular pager.

**Controlling activity tests:** An activity test function may attempt to generate activity by dialing a phone number or by activating a relay. As an example, the activity test that actuates a relay in an attempt to force activity would be that relay's controlling activity test.

**Controlling inputs:** An input may be programmed to actuate one or more relays if the input goes active. In such a situation, the input is termed a controlling input of the relay. A relay may have multiple controlling inputs.

**Delay State:** An input has been in the active level for a time period less than that input's specified time delay.

**Disabled State:** An input has not been enabled by the user.

**EIA (Electronics Industry of America):** An association in the US that establishes standards for electronics and data communications.

**Hard reset:** A hard reset completely reinitializes all memory to default values and erases any programming or history files that may have previously existed.

**Interval Between Calls:** The period between out bound alert call attempts (18).

**Isolators:** A device that separates one section of a system from undesired influences of other sections.

**Keyline:** The keyline carries the signal indicating that a transmitter should begin transmitting. Also frequently referred to as the Push-to-talk or PTT, monitoring this signal allows the monitor to qualify RF power inputs, as well as monitor and log transmitter On times.

**Latching:** In this manual, latching refers to the relay characteristic where a relay once activated by autonomous system command must be manually reset by the user using the Release Relay or Force Relay Off command.

## M-Z

**Major Alarm (MAJ):** The indication that an input has entered a major state.

**Major State:** An input is outside the allowable limits.

**Mapping:** Mapping is the programming a relationship between two or more I/O entities, generally to establish an automated response to an event. For instance, an input is said to be mapped to a relay if that input when active actuates the mapped relay.

**Minor Alarm (MIN):** The indication that an input has entered a minor state.

**Minor State:** An input is outside the allowable limits.

**Momentary (relay):** A relay type that will remain *on* for a specified duration.

**Normal Level (input):** The level at which an input normally operates.

**Normal State:** An input is within accepted limits.

**PBX (Private branch exchange) systems:** A line used as a trunk between a private branch exchange and the central office that serves it.

**POTS (Plain Old Telephone System) line:** This meaning the circuit switched single line usually found in residential installations. A PBX is not a POTS line and due to different status signalling may not support a POTS line device such as the *ProTekTor+*.

**PTT (Push-to-talk) line:** This line carries the signal indicating that a transmitter should begin transmitting. Also frequently referred to as the keyline, monitoring this signal allows the monitor to qualify RF power inputs, as well as monitor and log activity.

**Qualified (QUAL) :** The condition of one input being qualified by another input.

**Resonate cavities:** Tuned mechanical assemblies frequently installed on antenna feed lines to attenuate unwanted frequencies while passing the desired frequencies. Though cavities rarely fail catastrophically, they may drift off-frequency over time.

**Return-to-Normal Alarm (RTN):** The indication that an input has returned to normal.

**Soft reset:** A soft reset is simply a power cycle and does not reinitialize memory to default values or erase any programming or history files.

**Strobed:** A short duration activation of a relay, which in the *ProTekTor+* has a duration specified in the Relay Parameters Time field.

**TAPP (Telocator Alphanumeric Paging Protocol ):** The industry standard procedure for connecting to a paging terminal via dial up modem connection for the purposes of sending an alphanumeric page.

**TTL (Transistor-transistor-logic):** A popular logic circuit family that uses multiple-emitter transistors. A low signal state is defined as a signal 0.8V and below. A high signal state is defined as a signal +2.0V and above.

*ProTekTor+ Version 1.3*

# **Installation & Operations Manual**

---

© PageTek, Inc. 2000  
182-104 Wind Chime Court, Raleigh, NC 27615  
Telephone 919.518.1828 • Fax 919.846.5586  
Toll-free 1.888.572.7907  
<http://www.pagetek.net>



# Table of Contents

|  |           |   |              |
|--|-----------|---|--------------|
| Overview.....                                | CH 1      | <b>User Passwords.....</b>                  | <b>15</b>    |
| System Features.....                         | 1         | Name.....                                   | 15           |
|  |           | Password.....                               | 15           |
|  |           | <b>Alert-call Schedule List.....</b>        | <b>16</b>    |
|  |           | Schedule .....                              | 16           |
|  |           | Start Time.....                             | 16           |
|  |           | End Time.....                               | 16           |
|  |           | Days.....                                   | 16           |
|  |           | <b>Alert Call Parameters.....</b>           | <b>17-18</b> |
|  |           | Type.....                                   | 17           |
|  |           | Schedule Qual.....                          | 17           |
|  |           | Modem Number.....                           | 17           |
|  |           | Pager Number.....                           | 18           |
|  |           | Call Sequence.....                          | 18           |
|  |           | Attempts per number.....                    | 18           |
|  |           | Interval between calls.....                 | 18           |
|  |           | Sequence repetitions.....                   | 18           |
|  |           | <b>Status Call Parameters.....</b>          | <b>19</b>    |
|  |           | Number for status call.....                 | 19           |
|  |           | Date/time for next status call.....         | 19           |
|  |           | Interval in hours between status calls..... | 19           |
|  |           | <b>Inputs.....</b>                          | <b>20-22</b> |
|  |           | Description.....                            | 20           |
|  |           | Normal Level .....                          | 20           |
|  |           | Qlf By.....                                 | 21           |
|  |           | Time Dly.....                               | 21           |
|  |           | Alm Type.....                               | 21-22        |
|  |           | Enab.....                                   | 22           |
|  |           | Relays.....                                 | 22           |
|  |           | Sched.....                                  | 22           |
|  |           | <b>Relays.....</b>                          | <b>23-24</b> |
|  |           | Description.....                            | 23           |
|  |           | Type.....                                   | 23           |
|  |           | Time.....                                   | 24           |
|  |           | Controlling Inputs.....                     | 24           |
|  |           | Controlling Activity Tests.....             | 24           |
|  |           | <b>Input Activity Tests.....</b>            | <b>25-26</b> |
|  |           | Description .....                           | 25           |
|  |           | Inact Time.....                             | 25           |
|  |           | Force Activity.....                         | 26           |
|  |           | Wait Time.....                              | 26           |
|  |           | Maxact Time.....                            | 26           |
|  |           | Alarm Type.....                             | 26           |
|  |           | Enab.....                                   | 26           |
|  |           | Relay.....                                  | 26           |
| Installation.....                            | CH 2      |   |              |
| Pre-installation Inspection.....             | 3         |   |              |
| Pre-installation Set up.....                 | 4         |   |              |
| <b>Input Conditioning Configuration.....</b> | <b>4</b>  |   |              |
| On-Site Installation.....                    | 5         |   |              |
| <b>Interface Connector Installation.....</b> | <b>5</b>  |   |              |
| <b>PSTN (telephone) Installation.....</b>    | <b>5</b>  |   |              |
| <b>DC Power Cable Installation.....</b>      | <b>5</b>  |   |              |
| Optional Equipment Installation.....         | 5-6       |   |              |
| <b>Interconnection Options.....</b>          | <b>5</b>  |   |              |
| <b>Wall Mount AC Power Supply.....</b>       | <b>5</b>  |   |              |
| <b>Tower Light Sensor.....</b>               | <b>6</b>  |   |              |
| <b>Temperature Sensor.....</b>               | <b>6</b>  |   |              |
| <b>Telewave™ RF Power Sensor.....</b>        | <b>6</b>  |   |              |
| Post Installation Adjustments.....           | 7         |   |              |
| <b>RF Power Sensor Calibration.....</b>      | <b>7</b>  |   |              |
| Local VDT Set Up.....                        | 7         |   |              |
| Programming.....                             | CH 3      |   |              |
| Connecting.....                              | 9         |   |              |
| Logging In.....                              | 9         |   |              |
| Logging Out.....                             | 9         |   |              |
| Screen Navigation Commands.....              | 10        |   |              |
| System Initialization.....                   | 11-26     |   |              |
| <b>Password screen.....</b>                  | <b>11</b> |   |              |
| <b>Main Menu.....</b>                        | <b>11</b> |   |              |
| <b>Site Configuration.....</b>               | <b>12</b> |   |              |
| <b>Site Information.....</b>                 | <b>13</b> |   |              |
| Site ID.....                                 | 13        |   |              |
| Site Name.....                               | 13        |   |              |
| Date.....                                    | 13        |   |              |
| Time.....                                    | 13        |   |              |
| <b>System Parameters.....</b>                | <b>14</b> |   |              |
| Enable detailed TAPP log messages.....       | 14        |   |              |
| Enable alert calls .....                     | 14        |   |              |

# Table of Contents cont.

## Operation.....CH 4

|  |              |
|--|--------------|
| Routine Control .....                          | 27-35        |
| <b>Password screen.....</b>                    | <b>28</b>    |
| <b>Main Menu.....</b>                          | <b>28</b>    |
| <b>Site Configuration.....</b>                 | <b>29</b>    |
| <b>Commands.....</b>                           | <b>30-32</b> |
| 1. Acknowledge alert.....                      | 30           |
| 2. Pass through.....                           | 30           |
| 3. Delay modem auto-answer for 3 minutes ..... | 31           |
| 4. Write Memory.....                           | 31           |
| 5. Reset .....                                 | 31           |
| 6. Force relay on .....                        | 31           |
| 7. Force relay off .....                       | 31           |
| 8. Release relay.....                          | 31           |
| 9. Strobe relay.....                           | 31           |
| 10. Clear configuration.....                   | 32           |
| 11. Boot monitor.....                          | 32           |
| 12. Change idle time out for this session..... | 32           |
| 13. Calibrate analog inputs.....               | 32           |
| <b>Global Status screen.....</b>               | <b>33</b>    |
| Alert Calls.....                               | 33           |
| Relay.....                                     | 33           |
| State.....                                     | 33-34        |
| Controlling Inputs.....                        | 34           |
| Controlling Activity Tests.....                | 34           |
| Input Description.....                         | 34           |
| State.....                                     | 34-35        |
| Level.....                                     | 35           |
| Qlfd By.....                                   | 35           |
| Alert Active.....                              | 35           |
| Activity.....                                  | 35           |
| Active Today.....                              | 35           |
| Active Yesterday.....                          | 35           |

## Appendix.....A

|                                      |           |
|--------------------------------------|-----------|
| Configuration Plugs Description..... | 37        |
| Voltage to Wattage Tables.....       | 37        |
| <b>Uniform Voltage Scale.....</b>    | <b>37</b> |
| <b>Uniform Wattage Scale.....</b>    | <b>37</b> |
| Voltage - Temperature Table.....     | 37        |
| Board Layout.....                    | 38        |
| Front and Rear Panel Layouts.....    | 39        |
| Interface Connector Function.....    | 40        |
| Interface Connector Layout .....     | 41        |
| History Log Descriptions.....        | 42        |
| History Log Descriptions cont.....   | 43        |
| Special Characters.....              | 44        |
| Flash Upgrade Procedure.....         | 45        |
| Alert Call Message Structure.....    | 46        |

## Appendix.....B

|  |           |
|--|-----------|
| <b>Site Information Worksheet .....</b>          | <b>47</b> |
| <b>System Parameters Worksheet.....</b>          | <b>47</b> |
| <b>User Passwords Worksheet .....</b>            | <b>48</b> |
| <b>Input-Alert Schedule List Worksheet .....</b> | <b>49</b> |
| <b>Alert Call Parameters Worksheet.....</b>      | <b>49</b> |
| <b>Status Call Parameters Worksheet.....</b>     | <b>50</b> |
| <b>Inputs Worksheet.....</b>                     | <b>50</b> |
| <b>Relays Worksheet.....</b>                     | <b>51</b> |
| <b>Input Activity Tests Worksheet.....</b>       | <b>51</b> |

## Appendix.....C

|                       |           |
|-----------------------|-----------|
| <b>Addendums.....</b> | <b>53</b> |
|-----------------------|-----------|

## Appendix.....D

|                                      |              |
|--------------------------------------|--------------|
| Specifications.....                  | 55           |
| <b>Mechanical .....</b>              | <b>55</b>    |
| <b>Electrical.....</b>               | <b>55</b>    |
| <b>Interface Specifications.....</b> | <b>55-56</b> |

## Appendix.....E

|               |       |
|---------------|-------|
| Glossary..... | 57-58 |
|---------------|-------|